

MPanel-Pro v30

Table of Contents

Contents

1. MPanel General	3
What's New	3
Getting Started	6
Glossary	9
General Settings	11
License agreement	13
Contact List and Technical Contact us	19
1.7. MPanel Tools	20
Site Layout	20
Model Builder	25
Library Model Builder	36
Relax Mesh	38
Model Visualisation	43
Panel between Polylines	47
Panel Mesh	51
Merge Panels	54
Panel Arrange	56
Nesting	59
Modify Panel	62
Compensate Panels	67
Seam Allowance	69
Panel Stamp	72
Panel Output	74
Convert PolyLines	77
Convert Mesh/Polylines	80
Convert Meshes	82
Cross Section	85
Change Mesh Density	90

Information Button	92
Delete Old Objects.....	95
1.8. Technical Information	96
Modeling and Paneling Errors.....	96
Extended Data.....	97
Using Links.....	99
Links that simulate end width.....	102
Stress Estimation.....	107
Adding MPanel Pro to the AutoCAD Menu.....	108
Internal Model	109
CSA Internal Model Tension Calculations.....	109
Detail dxf specification.....	110
Scripting.....	111
Build barrel vault details explained.....	113
1.9. Quick Reference	114
Quick Reference (entities)	114
Quick Reference (tools).....	115

1. MPanel General

What's New

Version 30 (Mar 2026) summary of new features:

- Confirmed compatibility with AutoCAD 2027
- Optional edge bend detection for edge meshes [more....](#)
- Export and import setup files [more....](#)
- Corner clamp plates reinforcement patches now work with joined meshes for 5 and 6 corner sails
- Corner reaction line now shown on parametric clamp plate and corner disc reinforcement patches [more....](#)
- Corner reaction line now shown on panel modification tool... corner patch with radius [more....](#)
- Pre plugged plotter output settings for commonly used plotters selected by drop down [more....](#)
- Panel cuff mirror now works with 3-sided as well as 4-sided panels [more....](#)
- Extended data... copy to options now copies most of the special settings such as variable warp stress

Version 29.1 maintenance release:

- Some cross sections not lying in mesh plane, issue fixed
- Model build FSS missing hip polylines, issue fixed
- Split meshes for FSS left old mesh in drawing, issue fixed
- Geodesics failing when model has large offset from the origin, issue fixed
- Rhino interface updated to suit their change in specification at SR20

Version 29 (April 2025) summary of new features:

- Confirmed compatibility with AutoCAD 2026
- Draw Framed Shade Structure parametric model added to model builder [more....](#)
- Weft/Warp Stress ratio changed to Shape Factor with user friendly slider tool [more....](#)
- Split panels by specified fabric width either vertical or horizontal [more....](#)
- Split panels by number of evenly spaced panels either vertical or horizontal [more....](#)
- Split meshes for Framed Shade Structure models [more....](#)
- Orient warp directions of multiple meshes to vertical up (+Z) [more....](#)
- Orient warp directions of multiple meshes to same as "reference" green mesh [more....](#)
- Problem with added detail after seaming fixed

Version 28 summary of new features:

- Confirmed compatibility with AutoCAD 2025 including their change to net core
- Confirmed compatibility with Rhino 8 change to net core
- New Edge mesh with ruled surface produces single panels such as marine front screens with lower shear strain
- New Draw barrel vault provides parametric controls to build and panel barrel vaults
- New Mesh a frame tool automates meshing of simple framed structures
- New Make mirror cuff panel creates a panel of defined length mirrored from any edge
- Seam allowance corner truncation now includes a rebate option to truncate to fit hardware width
- Invert panel during nesting placed stamp text in wrong location, fixed
- Build panel from single entity could fail with simple entities such as rectangles, fixed
- Paneling error on completely flat panels fixed
- Export OBJ error fixed

Version 27.2 maintenance release:

- Seam styles and compensation settings sometimes fail to save on Win11 machines - made more robust
- Predefined layers weren't always specified correctly in AutoCAD - now fixed
- Misreading of decimal values when the windows locale specified a comma as a decimal point - now fixed
- Standard slits previously did not add 1st and last slit from panel edges - now included
- Panels in AutoCAD did not always use specified colors - now fixed

Version 27.1 update:

- Some MPanel tools caused panels to be grouped together in Rhino - now fixed

Version 27 summary of new features:

- Confirmed compatibility with AutoCAD 2024.
- New Tube tool provides simple tube modeling, intersection functions and control over tube seam location [more....](#)
- New panel modification tool, "Change panel edges" allows panel edges to be redefined [more....](#)
- Merge panels now has an option to cope with different number of nodes on the panel edges [more...](#)
- Split panel by edge lengths now retains both upper and lower panels.
- New panel seam/hem option square bottom offset seam ideal for adding valances [_more....](#)
- New mesh split tool splits mesh into segments ideal for applications such as the new Tube tool [more....](#)
- New combined cable and guy link for modeling cable nets.
- Cable link tension definition changed to be more intuitive [more....](#)
- Polyline conversion to radial lines (cartwheel) [more...](#)
- Button names optionally shown in toolbar for training along with "click here" notice on the title bar [more.....](#)
- Parametric site library image changed to isometric for improved clarity.
- Invert panels option added to nesting plus a warning if nested panels are output with the output setting "invert panels" on.
- Update License Agreement - continuing to use/update software confirms acceptance of the terms [refer.....](#)

Version 26.1 maintenance release:

- Panel a complete mesh diagonally could produce odd corner panels, now fixed
- Panel a set of polys could get the poly order incorrect, now fixed
- Panel a mesh diagonally including corner detail polys could give an error if only part of a poly appeared in a panel, now fixed
- Mesh relaxation with the option "straighten joined edges" went wrong if there were also fixed edges between meshes, now fixed
- Mesh to diagonal polys would fail if the draw layer was set to preserve layers, now fixed

Version 26 summary of new features:

- Confirmed compatibility with AutoCAD 2023
- Panel a complete mesh includes the choice to panel by "number of panels" or by a specified "fixed width"
- Panel a complete mesh will now pick up mid connections when a 3D poly is added to identify any mid

points

- "Straighten joined edges" tool added to mesh relaxation
- Panel from a set of color marked polys will automatically panel and number panels clockwise from a color
- Convert poly to points
- Draw edge mesh now includes the option to auto calculate N/M Surf based on edge tolerance
- Draw edge mesh based on intersecting curves

Version 25.1 maintenance release:

- DXF output tool has been updated to allow for different dxf file versions to be selected to suit different plotter/cutter requirements ([more details...](#))
- Minor bug repairs

Version 25 summary of new features:

- "Add Edge Mesh" tool updated to filter for edges so the CAD pick box ignores meshes or text.
- "Make panel from single entity" converts a single closed entity (circle, polygon, spline blob) into an MPanel standard panel.
- "Mirror mesh" takes some meshes (and 3dpolys and lines) and mirrors it while keeping the correct mesh orientation.
- "Join meshes tool" now works when joining meshes with different mesh density.
- Cross section tool now includes a new option called "Snap extra cross sections to points".
- The Poly Conversion tool now includes a new tool called "color mark duplicates" to mark duplicate polys for deletion.
- Extended data has been substantially updated and is now shown in property grid style.
- Other improvements include more consistent mesh naming - all meshes are now named M1, M2, M3.
- Users prompted to "panel across mesh" when paneling a mesh which has no left or right sides.

Version 24 summary of new features:

- Hole in mesh for visualization
- Advanced Conic - works on multiple circle-poly pairs, and joined meshes have same msurf
- Include corner angle in physical report in the info tool
- New poly constraint that defines the end of a cable for modeling calculations.
- Plot model with main seams and panel numbers superimposed on model
- Panel Numbers shown in the MPanel text window are now the Panel ID numbers.
- Push old objects to back of view in Rhino
- Easier to add diagonal cables - Mesh to poly can produce diagonal polys and Convert polys can convert poly to lines
- Added Panels marked on underside to swaps lap-over/lap-under
- Corner Plates and disks carry corner cable corrections to physical info report
- New Panel cutout tool added to Panel Modifications
- Panel multiple meshes now arranges the panels in a defined order

Getting Started



MPanel is a very flexible tool, used in different ways on different fabric projects. On your first use of MPanel you will be asked to set the units system that you use in your drawings. After that a typical job could go through the following steps:

- Start your CAD program and MPanel Pro.
- Draw the model in your CAD program using specified entities.
- Relax the model.
- Produce visualizations for client approval.
- Estimate a materials bill.
- Do a stress estimation.
- Create the panels.
- Compensate the panels.
- Apply a seam allowance.
- Stamp the panels.
- Output the panels.

Start your CAD program and MPanel Pro

To use MPanel Pro you need to first start your CAD program and then MPanel. MPanel Pro will appear as a floating toolbar, with buttons for each tool.

Basic MPanel Pro operation.

Left click on a toolbar button will run that tool with the current options.
Right click on a toolbar button will open the Options screen for that tool.

Holding the mouse over a button will show a drop down menu of the main tool options.
Left click on a drop down menu option will open the Options screen at the place for that menu option.

Help is available for each tool on the options screen for the tool and at the bottom of the drop down menu for each tool.

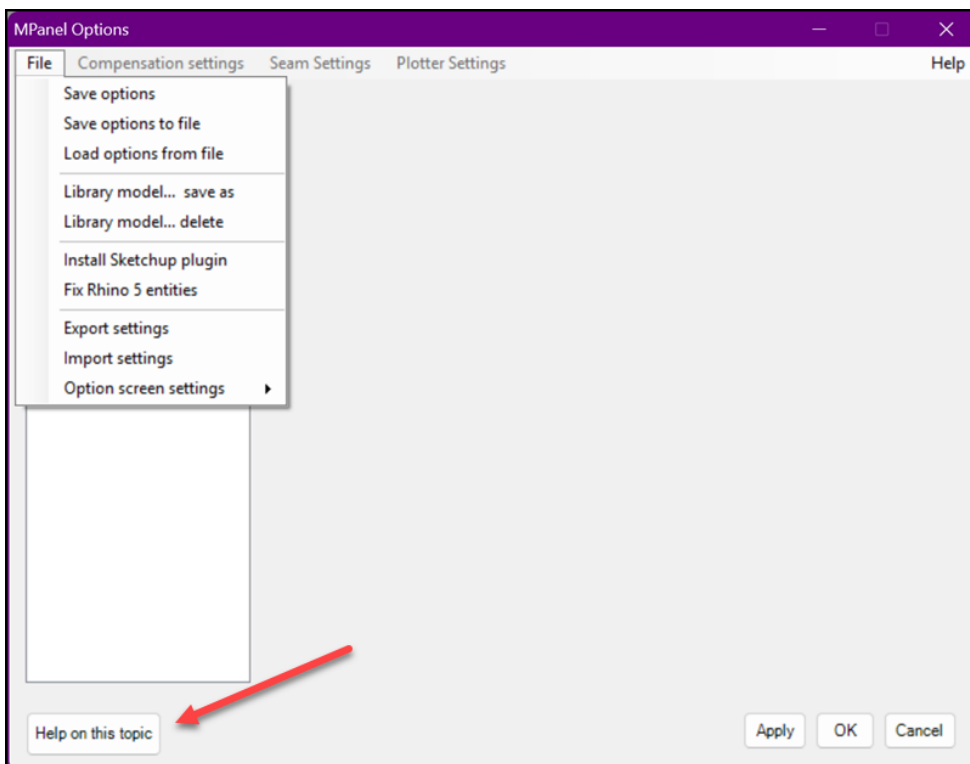

File Menu is available from the Options screen and provides several functions listed below:

- Save options saves current option settings as defaults for next time the program starts
- Save options to file allows user to save different options configurations for different projects
- Load options from file open and load previously saved settings files
- Library model save allows users to save multiple library models
- Library model delete allows users to delete library models
- Install Sketchup plugin plugin allows users to import MPanel models into Sketchup [...more](#)
- Fix Rhino5 entities MPanel entities saved in Rhino 5 can appear transparent in later Rhino versions
- Export settings allows user to save MPanel settings to a zip file for transfer MPanel to a new computer
- Import settings allows user to import MPanel settings zip file into new computer
- Option screen settings allows user to select if Options screen is always visible (i.e. in front of other app screens)

Toolbar utilities.

- Scripting functions ([see scripting](#))
- Show/Hide button names used during training
- Open help file

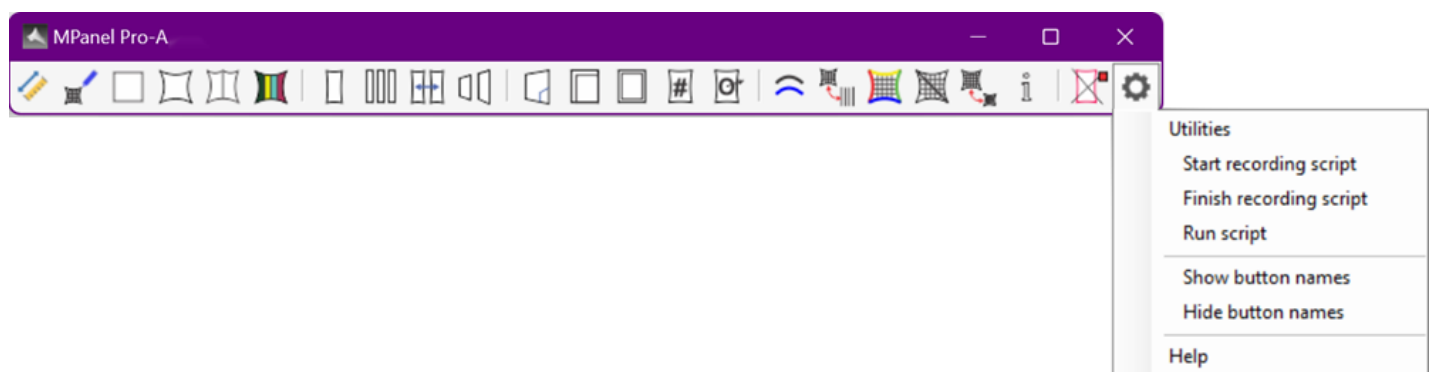

Draw the model in your CAD program using specified entities

An outline drawing is made using 3D polylines as fixed system points, lines as guy lines, and meshes as surfaces to relax. The [Model Builder](#) tool can help with this. Often the modeling process starts with drawing a 3d polyline around the fixed points, and building the model up from that. Also models can be built directly from the model library in the Model Builder.

Relax the model

Either [Relax Fixed Edge Mesh](#), [Relax Cable Edged Mesh](#) or [Relax Joined Edge Mesh](#) is used to relax (also known as form finding) the structure towards convergence. A few iterations are tried first to ensure that the model is correct, and then repeated relaxations until the model converges.

Produce visualisations for client approval

The relaxed model can be shaded or rendered in your CAD program. The drawing can be sent to other packages for walk-through's, and simulations, either in the native drawing format or as a DXF, drawing exchange format. (If you are using AutoCAD, the drawing can be Published or Published to Web)

Estimate a materials bill.

The [Info](#) tool will provide the total mesh area and cable lengths by using the "Whole Model Report" option.

Do a stress estimation

MPanel Pro is not a stressing package, but it does supply enough information for stress estimation to be made, as described in the [Stress Estimation](#) section. The "Whole Model Report" can also give useful indications of the possible stresses and cable tensions.

Create the panels

The panels can be created directly from the mesh, using [Mesh-Panel](#), or they can be defined by [cross sections or geodesic](#). These can be paneled directly using [Flat Panel](#), or they can be converted to another mesh with [mesh-lines](#), and then paneled.

Arrange the panels.

MPanel Pro draws the panels directly under the mesh or cross sections they came from, to ensure that the panel location in the build is correctly known. Often it is useful to arrange the panels in an ordered set, horizontally or vertically, with the [Arrange Panels](#) tool.

Compensate the panels

The panels are shrunk by a defined amount to introduce pre-stress into the structure. The amount of [compensation](#) depends upon the material properties of your fabric.

Apply a seam allowance

A [seam allowance](#) is added to the panel, and optionally, sewing balance marks, guidelines, and slits.

Stamp the panels

Before the panels are sent to production they will need annotation, warp orientation lines and other information adding. This is done by the [Panel Production](#) tool.

Output the panels

If the panels are going straight to a cutter then the panel may need modifying so that the cut information is distinct from the annotations, etc. The [Panel Output](#) tool takes care of these modifications.

Update CAD Software

If you update your version of CAD you will need to reinstall MPanel Pro software in order for the MPanel Pro program to register with the new CAD software. Re-installations are handled in the same way as the original software installation. After installing your new CAD program, logon to your Dashboard on [mpanel.com](#) and download the latest MPanel Pro software version to your downloads folder (see video below). With CAD turned off, run the setup installer and follow the instructions. Once completed, start CAD then start MPanel. There is no need to Authorize the re-installation as it will pick up the license already assigned to the computer.

Update MPanel Pro Software

MPanel Pro frequently updates the software to ensure compatibility with operating and CAD system changes and to improve and add features. These updates are released as major updates (integer changes in the version number e.g. V25 to V26) or as minor version updates including bug fixes or minor improvements which can be identified by incremental decimal version numbers e.g. V26.1, V26.2 etc. Software updates are handled in the same way as the original software installation. When notified of a software update, logon to your Dashboard on [mpanel.com](#) and download the latest software version to your downloads folder (see video below). With CAD turned off, run the setup installer and follow the instructions. Once completed, start CAD then start MPanel.



Video: [install and update software](#)

Move software license to a new or updated computer

MPanel Pro software licenses are assigned to the computer hardware used to first register the license. In order to move your license to another computer there are 3 steps we need to take.

1st - you should log onto your Dashboard and download the software and your license key so you can install on the new machine.

2nd - identify the computer name of your old computer - [how to find computer name](#)

3rd - when you are ready to move to your new computer, let us know your old computer name and we will make contact with the license server and request that your old computer be removed from the license database so it will be free to be authorized on your new machine.

Note - only notify us after you have stopped using the old computer otherwise, the license will be retaken by the old computer as soon as we release the old hardware.

Note - this service is provided at no cost to users with a current support subscription up to 5 times per year. Users with a lapsed support subscription will need to purchase a casual support event from their Dashboard page on mpanel.com and let us know after the payment has been made.

Glossary

Fabric Terms

Shear strain

The amount that a fabric is distorted such that a square in the fabric becomes a parallelogram or rhomboid

Warp

The direction along the length of a fabric

Weft

The direction across the width of a fabric

Tensile Structure Terms

Anticlastic

A 3D shape similar to a saddle, with positive and negative principle curvatures

Cross section

The curve produced by cutting a 3D surface with a plane, often a vertical plane

Geodesic

The shortest path between two points on a curved 3D surface

MPanel Pro Terms

Balance marks

Marks placed on the panel edges to help with lining up during manufacture

Coincident

The placing of one node directly on top of another node

Compensate

The deliberate shrinking of panels, to introduce pre stress when they are stretched to fit

Converge

Move towards a final stable shape

Interpolated polyline

A polyline approximation to a spline

Iteration

One run through the relaxation program. Typically 100 iterations are done in one go.

Links

A structural member that has the properties of length and tension only.

Merge

The process of joining together two adjacent panels, that typically will not fit together exactly

Edge Mesh

A mesh drawn between 4 edges. The edges can be any non closed CAD entity

Corner Mesh

A mesh drawn between 4 corners

Fixed Edge Mesh

A mesh with all edges assumed to be fixed

Cable Edge Mesh

A mesh with all edges assumed to be cables

Joined Edge Mesh

A mesh with all edges assumed to be cables, unless they join another mesh at the corners.

Stamp

The preparation of a panel for production

Relax

The process of allowing the mesh and links to move in 3D space until a force balance is found at each node

Tick marks

Marks placed on the panel edges to help with lining up during manufacture

Slits

Cuts made in a seam to allow the folded seam to follow a curve

AutoCAD specific terms.

Blocks

A collection of entities that are to be regarded as a single object

Entities

A visible geometry object in AutoCAD

Nodes

The defining points in an entity, ie for a line the start and end points

Polylines

An entity composed of one or more connected line segments treated as a single object

3D polyline

A polyline with nodes in 3 dimensions of x, y and z

LW polyline

A polyline with nodes in 2 dimensions x and y, drawn in a 3 dimensional plane

2D polyline

A polyline with nodes in two dimensions, x and y, with a fixed z elevation

Spline

A smooth curve passing through a set of nodes

Visualisation

The process of rendering, shading and viewing from different viewpoints.

Rhino specific terms.

Blocks

A collection of entities that are to be regarded as a single object

Entities

A visible geometry object in Rhino

Point

The defining points for an entity, used to adjust the entity or to OSnap another entity to.

Or a point entity drawn in 3D space

Polylines

A curve with more than two points, with degree =1.

Spline

A smooth curve passing through a set of points

Visualisation

The process of rendering, shading and viewing from different viewpoints.

General Settings

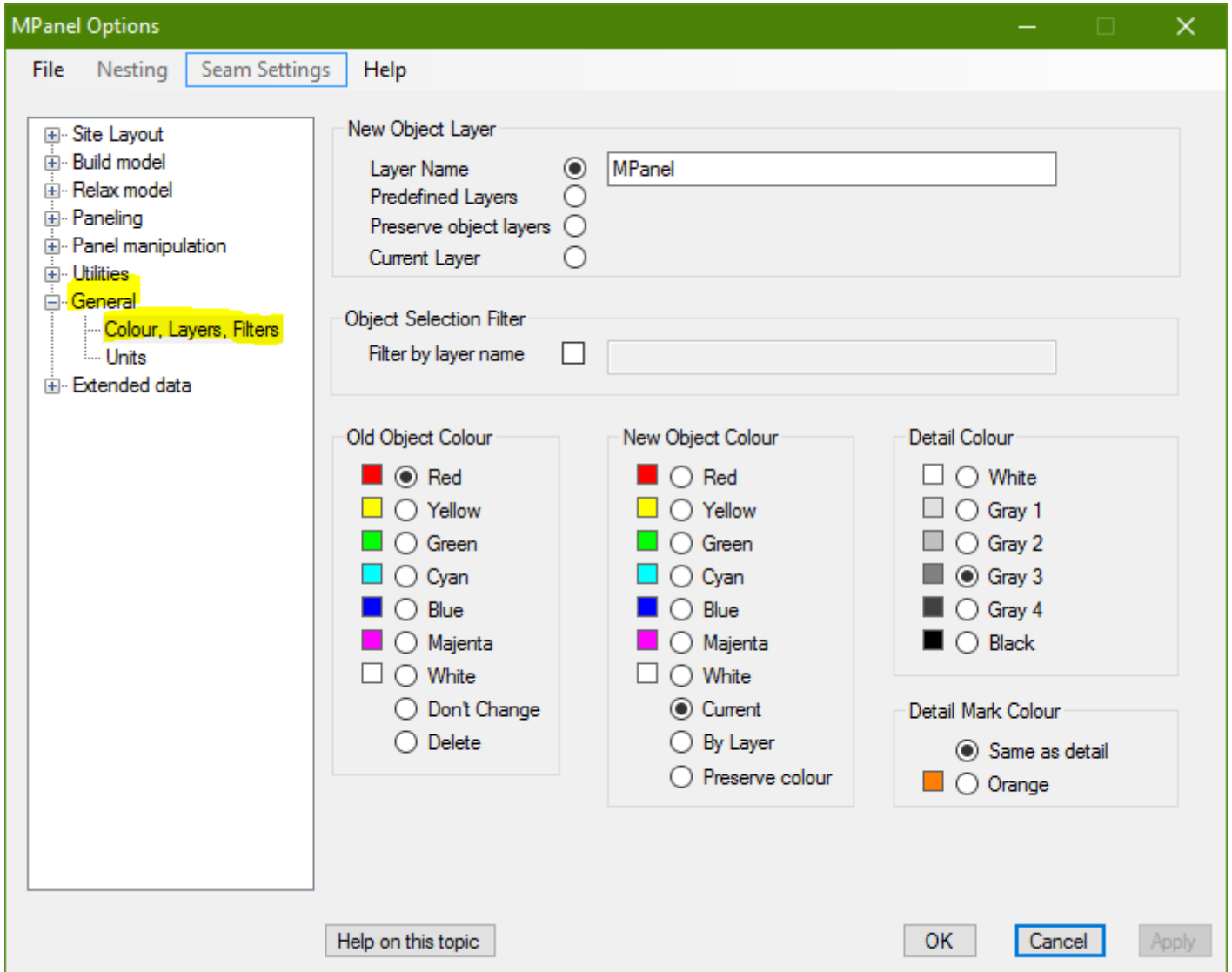

On the general settings tab we can define how MPanel Pro draws entities in the your CAD drawing. You can make settings for:

- New Object Layer
- Old Object Color
- New Object Color
- Detail Color
- Default Units
- Selection Filter

New Object Layer

Defines the layer that MPanel Pro will draw new entities onto. If the layer doesn't exist, it will be created. Choice of:

Named Layer

uses the layer name specified. Often set to "Development" or "MPanel"

Predefined Layers
etc.

uses different predefined layers for Building ,Relaxing, Paneling,

Preserve Object layers

keeps the same object layer for meshes, lines, or derived objects.

Current Layer

uses the current CAD drawing layer

Old Object

Defines the color to identify the old object. Often set to "Red"

Can also be set to delete the old object.

New Object Color

Defines the color to draw the new object. Often set to "Current"

Can also be set to "By Layer" , so the display color will be defined by the New Object Layer.

Can also be set to "Preserve color" so the new object color is the same as the object it was derived from.

Detail Color

Defines the grey to draw panel detail, and extra cross sections in. Often set to a mid .

Additionally detail used to define marks during seaming can be colored Orange.

Default Units

Allows you to set the default values, and prompts, to the unit system that you use. Select the units and click on "Set". If you have previously saved a set

Selection Filter

Allows you to filter the selection set by layer name. This can be useful when working in a dense drawing with a lot of extra details (columns, nuts, bolts etc) that are not required by MPanel.

Notes for advanced users:

If you normally use layer colors, MPanel Pro will maintain them if you set:

New Object Layer = Preserve Layers

New Object Color = ByLayer

For the fastest drawing of complicated models, use:

New Object Layer = Current

New Object Layer = Current

Color Old Object = OFF

The predefined layers can be tailored by hand editing the MPanel Pro User Setting.ini file, in the users documents directory. By default they are:

Model Builder = "MP_Model"

Relaxed Models = "MP_Relax"

Basic Panels = "MP_Panel"

Compensated Panels = "MP_Comp"

Seamed Panels = "MP_Seam"

Stamped Panels = "MP_Stamp"

Utility Tools = "MP_Utility"

License agreement

MPanel Pro Software Solutions LLC License Agreement

This is a legally binding software License agreement (the "License") between the following parties:

- (1) MPanel Pro Software Solutions LLC of 3615 Queens Hwy., Carlsbad, NM 88220 U.S.A. ("MPanel", "we" or "us" or "Licensor"). We are a company registered in New Mexico with identification number 821926203; and
- (2) You (either as an individual or a single entity), being a user of the MPanel Pro Software as defined below.

PLEASE READ THIS LICENSE CAREFULLY.

IF YOU DO NOT ACCEPT THE TERMS OF THIS LICENSE, DO NOT INSTALL OR USE THE MPanel Pro SOFTWARE.

BY USING THE MPanel Pro SOFTWARE YOU AGREE TO BE BOUND BY THIS LICENSE.

MPanel Pro Software means any software provided with this License, such as by way of download, on disk, flash drive or through any other media or format, including any software, code, interfaces or Content and whether owned by us or by a third party.

Content means any content, text, documents, fonts, graphics, images, video, footage, audio, media files, data, templates, clipart, photographs, names, images, trademarks, links, or similar.

Your Rights and Permitted Use

1. You are licensed to use the MPanel Pro Software as expressly set out in this License from your first use of the MPanel Pro Software until termination of this License.
2. No rights in the MPanel Pro Software are sold to you; your right is solely to use the MPanel Pro Software within the terms of this License. All rights not expressly granted to you are reserved to MPanel.
3. The License granted to you is limited, non-transferable and non-exclusive. Except to the extent any rights cannot be excluded by law, you are permitted:
 - (i) if you are a private individual, to download, install, use and run for personal use, one (1) copy of the MPanel Pro Software on a computer running Microsoft Windows ("Windows Computer") that you personally own or control at your location for each seat authorized by MPanel.
 - (ii) if you are a commercial enterprise, to download, install, use and run one (1) copy of the MPanel Pro Software for use by a single individual on a Windows Computer that they use that you own or control at your location for each seat authorized by MPanel. A maximum of 10 seats can be authorized per license and separate licenses are required for each additional location you operate equipment owned by you.
 - (iii) if you are an educational institution, to download, install, use and run, one (1) copy of the MPanel Pro Software for use by a single individual on a Windows Computer that they use that you or they own or control for each seat authorized by MPanel. Commercial use is not permitted.
4. Except to the extent expressly allowed in this License:
 - a. you are not permitted to run, or allow to be run, the MPanel Pro Software over a network or any other means by which it can be used simultaneously on more than one computer; and

- b. you have no right to rent, lend, lease, sell, supply, transfer or distribute, transfer, redistribute or sublicense the MPanel Pro Software.
- c. the license is restricted to use for your own purpose and is not to be used for the sale of design services to other potential license holders.

5. The MPanel Pro Software is protected by United States and international copyright and other applicable laws. All title and intellectual property rights, including copyright, in the MPanel Pro Software are owned by MPanel Pro or its licensors.

6. You must not use the MPanel Pro Software in a way that may infringe the copyright of a third party, such as by copying, reproducing, adapting, publishing, issuing copies of, communicating, exhibiting, transmitting, or distributing copyright materials without permission of the copyright owner. It is your responsibility to ensure that your use of the MPanel Pro Software does not infringe the rights of third parties; you should take any necessary legal advice in this respect.

7. Where you use the MPanel Pro Software to display or access Content, you acknowledge that the Content may be owned by third parties, may be protected by copyright and/or other intellectual property rights and may be subject to conditions of use. Other than as expressly set out in this License, you are not granted any rights to use such Content and no representation is made that any Content will continue to be made available to you. MPanel Pro is not responsible for any third party Content and any access to it provided by MPanel Pro is provided solely as a convenience and the provision of such access does not imply any endorsement by MPanel.

8. The MPanel Pro Software may be supplied in different versions or subject to further specific License terms. For example, the MPanel Pro Software may be supplied:

- a. as a trial, locked, demonstration or other limited use version ("Trial Version"); or
- b. as a student, teacher, OEM/Bundle Purchase version or other version dependent on status or intended use ("Customer Specific Version"); or
- c. as part of a volume or maintenance License or as part of use of other services provided by MPanel Pro ("Volume License").

In the case of all Trial Versions, Customer Specific Versions, Volume Licenses or software supplied under other specific arrangements, then this License will still apply but shall be subject to any terms on which such MPanel Pro Software is supplied including any terms set out on the website from which the MPanel Pro Software is downloaded or on the packaging of the MPanel Pro Software or otherwise as agreed with MPanel. In the case of Trial Software, this License will terminate after any period specified as part of the trial or demonstration. In the case of Customer Specific Software, this License will only take effect if and to the extent at the time of purchase you satisfy any stipulated status requirements; if you are in any doubt as to whether your status at the time of purchase entitles you to use a Customer Specific Version then please contact MPanel Pro support for further information in advance of making a purchase.

9. Except to the extent necessary for the normal and permitted use of the MPanel Pro Software or to the extent that such right cannot be excluded by law or to the extent required to be permitted by licensing terms governing use of open source components that may be included with the MPanel Pro Software:

- a. You have no right (and shall not permit any third party) to copy, adapt, amend, reverse engineer, decompile, disassemble, attempt to derive the source code of, create derivative works of, decrypt, modify, distribute or make error corrections to any aspect of the MPanel Pro Software in whole or in part; and
- b. You have no right to a copy of any of the MPanel Pro Software, or of any algorithms or code or other material relating to the MPanel Pro Software.

10. Where you are supplied with any updates, upgrades or new versions of the MPanel Pro Software, the terms of this License shall apply to the use of such updates, upgrades or new versions unless new License terms accompany such updates, upgrades or new versions, in which case the new License terms will apply to all use of the updated, upgraded or new version of the MPanel Pro Software. Nothing in this

License shall require MPanel Pro to supply you with updates, upgrades or new versions.

11. You will comply with all laws and regulations when downloading, installing, and using the MPanel Pro Software, including any laws and regulations specific to your location of download. You must not use the MPanel Pro Software in any way to publish or transmit any illegal material or links to such material, nor to infringe the rights (including intellectual property rights) of any third party.

12. MPanel Pro (or its licensors) may suspend, remove, modify, or disable (or impose limits on) access to the currently available MPanel Pro Software at any time without notice and without liability to you.

Consent to Use of Data

13. During normal MPanel Pro Software operation, standard computer information is passed to our server, including Hardware ID, Computer Name, and User Name. This information will be used by MPanel Pro and its subsidiaries and affiliates solely for program authorization. This information will not be transferred to third parties. You agree that MPanel Pro and its affiliates may use any information you give to us as part of product support and other services provided to you, if any, related to the MPanel Pro Software solely to improve products or to provide customised services or technologies to you and will not disclose this information in a form that personally identifies you.

Termination

14. This License will terminate automatically on any material breach by you of its terms.

15. On termination, you must cease all use of the MPanel Pro Software and delete all copies in your possession.

16. Any provision of this License which expressly or by implication is intended to come into or continue in force on or after termination of this License shall remain in full force and effect.

WARRANTIES AND LIMITS OF LIABILITY

17. NOTHING IN THIS LICENSE SHALL OPERATE TO EXCLUDE OR LIMIT EITHER PARTY'S LIABILITY FOR:
a. DEATH OR PERSONAL INJURY CAUSED BY ITS NEGLIGENCE; OR
b. FRAUD; OR
c. ANY OTHER LIABILITY WHICH CANNOT BE EXCLUDED OR LIMITED UNDER APPLICABLE LAW.
ALL TERMS OF THE LICENSE SHALL TAKE EFFECT SUBJECT TO THIS.

18. LOCAL LAWS MAY APPLY TO PROTECT THE RIGHTS OF INDIVIDUALS WHO PURCHASE THE MPanel Pro SOFTWARE IN THEIR INDIVIDUAL CAPACITY OUTSIDE A COMMERCIAL ENTERPRISE, SUCH AS CONSUMERS. NOTHING IN THIS LICENSE SHALL OPERATE TO EXCLUDE OR REDUCE SUCH PROTECTION. IF YOU THINK THIS MAY APPLY TO YOU, PLEASE CONSULT A CONSUMER ADVICE ORGANISATION.

19. THE MPanel Pro SOFTWARE ARE SUPPLIED TO YOU "AS IS" AND "AS AVAILABLE" WITH ANY AND ALL FAULTS AND DEFECTS AND WITHOUT ANY WARRANTIES BY MPanel Pro OR ITS LICENSORS OF ANY KIND.

20. IT IS YOUR RESPONSIBILITY TO ENSURE THE MPanel Pro SOFTWARE PERFORM THE PURPOSE FOR WHICH THEY ARE REQUIRED AND WILL FUNCTION PROPERLY IN THE ENVIRONMENT IN WHICH THEY ARE TO BE USED. THEIR USE IS AT YOUR SOLE RISK AND YOU ARE RESPONSIBLE FOR ANY COST OF REPAIR, CORRECTIONS OR SERVICING. YOU ACKNOWLEDGE INSTALLATION OF THE MPanel Pro SOFTWARE MAY AFFECT THE USABILITY OF THIRD PARTY SOFTWARE OR THIRD PARTY SERVICES. . IT IS YOUR RESPONSIBILITY TO ensure that any structure designed and built using the MPanel Pro Software is built to a satisfactory standard. In particular, the materials, corner connecting hardware, poles and ground footings

should be sufficient to resist expected environmental loads such as wind and snow with an adequate safety margin. YOU ARE responsible for meeting any applicable building codes and regulations, obtaining any required building permits, and meeting any applicable engineering specifications. Note that the MPanel Pro Software supplies no guidance or information on the matters mentioned in this paragraph at all.

21. WITHOUT LIMITATION, PLEASE NOTE THAT NO REPRESENTATION OR WARRANTY IS GIVEN BY MPanel Pro OR ITS LICENSORS THAT:

- a. THE MPanel Pro SOFTWARE WILL MEET YOUR REQUIREMENTS; OR
- b. ANY INFORMATION OR DATA PROVIDED WITH THE MPanel Pro SOFTWARE IS ACCURATE, ERROR FREE OR COMPREHENSIVE; OR
- c. OPERATION OF THE MPanel Pro SOFTWARE WILL BE UNINTERRUPTED OR ERROR FREE; OR
- d. ANY CONTENT AVAILABLE FOR DOWNLOADING FROM US IS FREE FROM VIRUSES OR ANY OTHER CONTAMINATION OR DESTRUCTIVE FEATURES; OR
- e. YOU WILL ENJOY THE USE OF THE MPanel Pro SOFTWARE FREE FROM INTERFERENCE; OR
- f. THE MPanel Pro SOFTWARE WILL CONTINUE TO BE MADE AVAILABLE OR MAINTAINED OR SUPPORTED OR THAT ANY DEFECTS WILL BE CORRECTED; OR
- g. THE MPanel Pro SOFTWARE WILL BE COMPATIBLE WITH ANY THIRD PARTY SOFTWARE, THIRD PARTY SERVICES, THIRD PARTY EXTERNAL SERVICES OR MPanel Pro EXTERNAL SERVICES;
- h. THE MPanel Pro SOFTWARE OR MPanel Pro EXTERNAL SERVICES OR THIRD PARTY EXTERNAL SERVICES WILL BE AVAILABLE OR ACCESSIBLE IN ANY LANGUAGE OR FROM ANY LOCATION OR ARE APPROPRIATE FOR USE IN ANY LOCATION.

22. TO THE EXTENT POSSIBLE UNDER THE APPLICABLE LAW, ALL CONDITIONS, WARRANTIES OR OTHER TERMS WHICH MIGHT HAVE EFFECT BETWEEN THE PARTIES OR BE IMPLIED OR INCORPORATED INTO THIS LICENSE OR ANY COLLATERAL CONTRACT, WHETHER BY STATUTE, COMMON LAW OR OTHERWISE, ARE HEREBY EXCLUDED, INCLUDING ANY IMPLIED CONDITIONS, WARRANTIES OR OTHER TERMS AS TO SATISFACTORY QUALITY, FITNESS FOR PURPOSE OR THE USE OF REASONABLE SKILL AND CARE.

23. MPanel Pro AND ITS LICENSORS WILL NOT BE LIABLE FOR ANY LOSS OR DAMAGE CAUSED BY A DISTRIBUTED DENIAL-OF-SERVICE ATTACK, VIRUSES OR OTHER TECHNOLOGICALLY HARMFUL MATERIAL THAT MAY INFECT ANY SITE, COMPUTER EQUIPMENT, COMPUTER PROGRAMS, DATA OR OTHER PROPRIETARY MATERIAL DUE TO YOUR USE OF THE MPanel Pro SOFTWARE.

24. MPanel Pro AND ITS LICENSORS SHALL HAVE NO LIABILITY FOR ANY LOSSES OR DAMAGES WHICH MAY BE SUFFERED BY YOU (OR ANY PERSON CLAIMING UNDER OR THROUGH YOU), WHETHER THE SAME ARE SUFFERED DIRECTLY OR INDIRECTLY OR ARE IMMEDIATE OR CONSEQUENTIAL, AND WHETHER THE SAME ARISE IN CONTRACT, TORT (INCLUDING NEGLIGENCE) OR OTHERWISE HOWSOEVER, WHICH FALL WITHIN ANY OF THE FOLLOWING CATEGORIES: I) SPECIAL DAMAGE EVEN THOUGH MPanel Pro WAS AWARE OF THE CIRCUMSTANCES IN WHICH SUCH SPECIAL DAMAGE COULD ARISE; II) LOSS OF PROFITS; III) LOSS OF ANTICIPATED SAVINGS; IV) LOSS OF BUSINESS OPPORTUNITY; V) LOSS OF GOODWILL; OR VI) LOSS OR CORRUPTION OF DATA.

25. THE TOTAL LIABILITY OF MPANEL, WHETHER IN CONTRACT, TORT (INCLUDING NEGLIGENCE) OR OTHERWISE AND WHETHER IN CONNECTION WITH THIS LICENSE OR ANY COLLATERAL CONTRACT, SHALL IN NO CIRCUMSTANCES EXCEED THE TOTAL SUMS PAYABLE BY YOU TO US FOR USE OF THE MPanel Pro SOFTWARE.

26. YOU AGREE THAT, IN ENTERING INTO THIS LICENSE, EITHER YOU DID NOT RELY ON ANY REPRESENTATIONS (WHETHER WRITTEN OR ORAL) OF ANY KIND OR OF ANY PERSON OTHER THAN THOSE EXPRESSLY SET OUT IN THIS LICENSE OR (IF YOU DID RELY ON ANY REPRESENTATIONS, WHETHER WRITTEN OR ORAL, NOT EXPRESSLY SET OUT IN THIS LICENSE) THAT YOU SHALL HAVE NO REMEDY IN RESPECT OF SUCH REPRESENTATIONS AND (IN EITHER CASE) MPanel Pro SHALL HAVE NO LIABILITY OTHER THAN IN ACCORDANCE WITH THE EXPRESS TERMS OF THIS LICENSE.

Government End Users

27. The MPanel Pro Software and related documentation are "Commercial Items", as that term is defined at 48 C.F.R. §2.101, consisting of "Commercial Computer Software" and "Commercial Computer Software Documentation", as such terms are used in 48 C.F.R. §12.212 or 48 C.F.R. §227.7202, as applicable. Consistent with 48 C.F.R. §12.212 or 48 C.F.R. §227.7202-1 through 227.7202-4, as applicable, the Commercial Computer Software and Commercial Computer Software Documentation are being licensed to U.S. Government end users (a) only as Commercial Items and (b) with only those rights as are granted to all other end users pursuant to the terms and conditions herein. Unpublished-rights reserved under the copyright laws of the United States.

Miscellaneous

28. This License and the License granted pursuant to this License are personal to you and except where expressly permitted you shall not assign the benefit of or any interest or obligation under this License.

29. Apart from MPanel's licensors and authorised distributors, a person who is not a party to this License has no right under the Contracts (Rights of Third Parties) Act 1999 or otherwise to enforce any term of this License. The consent of any third party is not required for any variation (including any release or compromise of any liability under this License) or termination of this License.

30. All disclaimers of warranties, limitations and exclusions of damages, rights to be indemnified by you and dispute resolution shall apply to MPanel's licensors, suppliers, vendors, authorised distributors and resellers, all of which shall be deemed express third party beneficiaries thereof.

31. If any court or competent authority finds that any provision of this License (or part of any provision) is invalid, illegal or unenforceable, that provision or part-provision shall, to the extent required, be deemed to be deleted, and the validity and enforceability of the other provisions of this License shall not be affected.

32. Except where expressly stated, no variation of this License shall be effective unless it is in writing and signed by the parties (or their authorised representatives).

33. No failure or delay by a party to exercise any right or remedy provided under this License or by law shall constitute a waiver of that or any other right or remedy, nor shall it preclude or restrict the further exercise of that or any other right or remedy.

34. This License (including any documents referred to in the License) contains the whole agreement between the parties relating to the subject matter hereof and supersedes all prior agreements, arrangements and understandings between the parties relating to that subject matter.

35. a) References to MPanel Pro and you includes their permitted successors and assigns; b) references to statutory provisions include those statutory provisions as amended or re-enacted; c) references to one gender includes a reference to the other genders; d) references to "including" or "includes" shall be deemed to have the words "without limitation" inserted after them; e) words in the singular include the plural and those in the plural include the singular; and f) a person includes a natural person, corporate or unincorporated body (whether or not having separate legal personality) and that person's personal representatives, successors or permitted assigns.

36. This License and any connected dispute shall be governed by and construed in accordance with the laws and courts of New Mexico, United States. Where any translations of this License are provided, the content of the English version shall take priority in cases of conflict, to the extent not prohibited by any local

laws.

37. You agree that You will not export or transmit the MPanel Pro Software or any Applications, directly or indirectly, to any restricted countries or in any manner that would violate United States laws and regulations as shall from time to time govern the license and delivery of technology abroad by persons subject to the jurisdiction of the United States government, including the Export Administration Act of 1979, as amended, and any applicable laws or regulations issued thereafter.

Contact List and Technical Contact us

Technical support is available to customers who:

Have a valid annual technical support contract
or purchased MPanel Pro within the previous 12 months
or are evaluating an MPanel Pro demo product.

In general, it is best to send the drawing showing the question as an attachment to the email, as this will allow us to respond specifically to your question. We will usually mark up the drawing and send it back to you

Support questions should be sent to:

support@mpanel.com

1.7. MPanel Tools

Site Layout

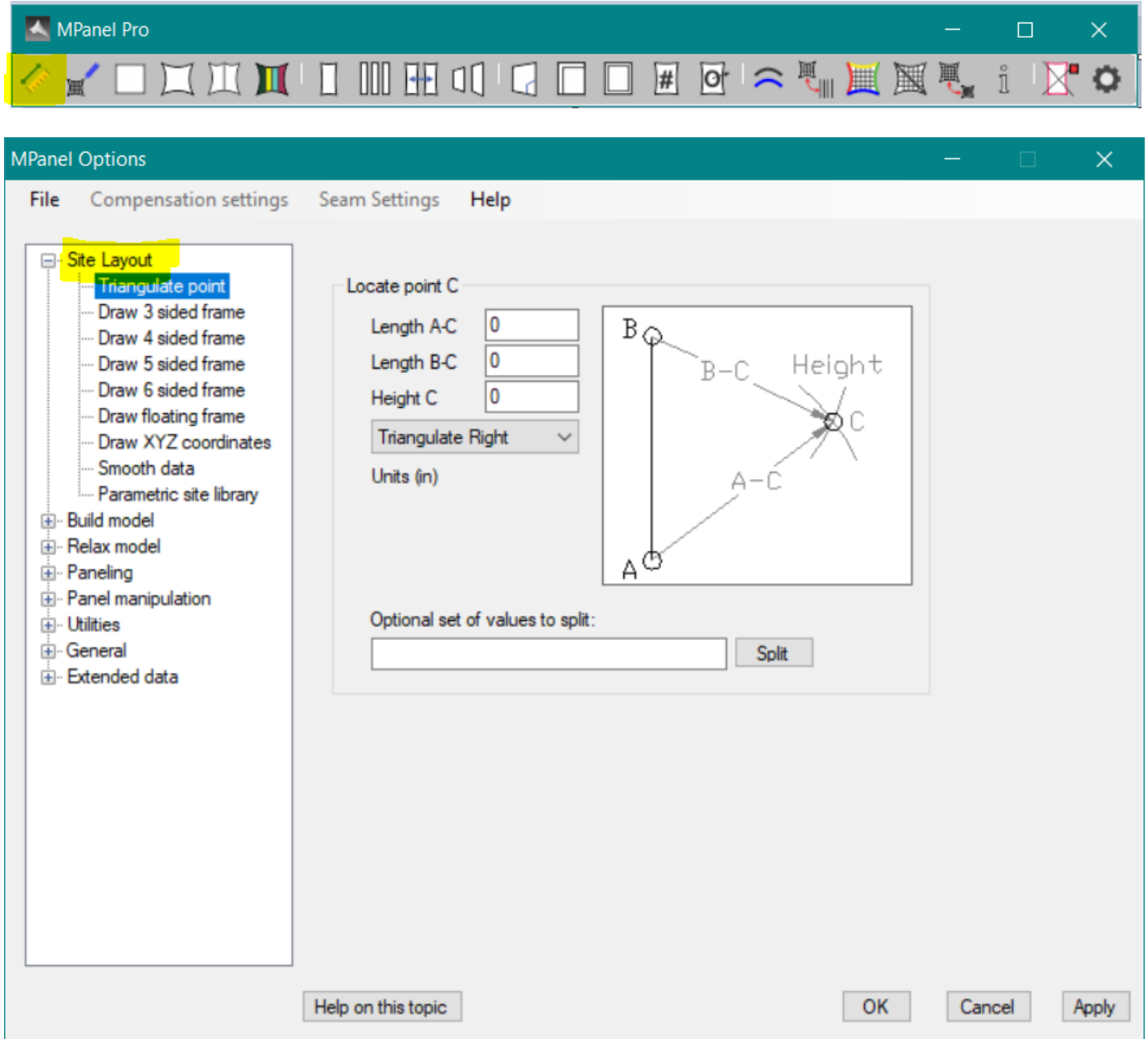

Site layout is a set of tools that assist with getting the site measurements converted into an outline CAD drawing. It can perform the following functions:

- Triangulate a point
- Draw 3 sided frame
- Draw 4 sided frame
- Draw 5 sided frame
- Draw 6 sided frame
- Draw 4 sided floating frame
- Draw XYZ coordinates
- Smooth machine measured data
- Parametric site library

Triangulate a point

A common measuring method is to define a point by measuring straight line distances from two known points, and measuring the height of the unknown point. At its simplest this can be done with a tape measure and level, or electronic distance measuring equipment can be used.

We define points A and B as known, and supply lengths A-C B-C and height C. Running the tool and selecting points A and B in the drawing will create an outline 3d poly to point C. You can select if this point is to the right or left of line A-B

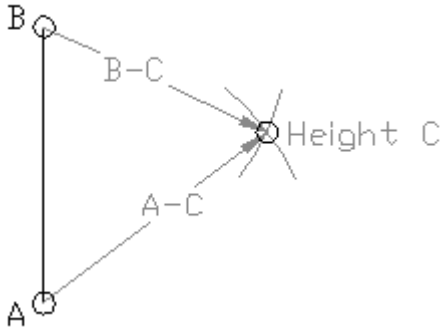

This process can be repeated many times to build up a 3d frame image from a set of site measurements. A set of site measurements would often be recorded in a spreadsheet, a facility to split a line containing the 3 values is supplied.

When the process is repeated many times, it is good practice to make the final measurements to a pair of points that have a known separation. Measuring this separation in the drawing will give an indication of the accumulated measurement errors.



Video: [Site Layout - shade sail frame models builders](#)

Draw 3 sided frame

We define a triangle with points A, B, C and enter values for lengths A-B, B-C, C-A and heights of A, B, C. The program will then draw the triangle as a 3d poly frame, optionally with the poles drawn as well.

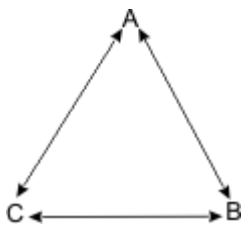

If A, B, C are poles, the most accurate measurements are obtained at the pole tops. This allows for any pole lean or manufacturing errors. Alternatively you can make the measurements at the pole bottoms.

The "Check Measurements" button will confirm that the measurements are consistent, ie that they can produce a valid triangle.

Example measurements can be imported to show how the tool works.

Draw 4 sided frame

We define a quadrilateral with points A, B, C, D and enter values for edge lengths A-B, B-C, C-D, D-A and diagonals A-C, B-D and heights of A, B, C, D. The program will then draw the quadrilateral as a 3d poly frame.

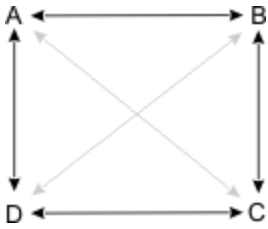

If A, B, C, D are poles, the most accurate measurements are obtained at the pole tops. This allows for any pole lean or manufacturing errors. Alternatively you can make the measurements at the pole bottoms.

The "Check Measurements" button will confirm that the measurements are consistent, ie that they can produce a valid quadrilateral. Because we have one more measurement than is strictly necessary to define the quadrilateral, we can also report the measurement accuracy.

Example measurements can be imported to show how the tool works.

Draw 5 sided frame

We define a 5 sided frame with points A, B, C, D, E and enter values for the appropriate edge lengths, diagonals and pole heights. The program will then draw a 3d poly frame, optionally with the poles drawn as well.

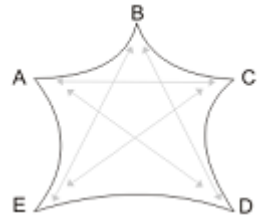

If A, B, C, D, E are poles, the most accurate measurements are obtained at the pole tops. This allows for any pole lean or manufacturing errors. Alternatively you can make the measurements at the pole bottoms.

The "Check Measurements" button will confirm that the measurements are consistent, ie that they can produce a valid 5 sided frame. Because we have one more measurement than is strictly necessary we can also report the measurement accuracy.

Example measurements can be imported to show how the tool works.

Draw 6 sided frame

We define a 6 sided frame with points A, B, C, D, E, F and enter values for the appropriate edge lengths, diagonals and pole heights. The program will then draw a 3d poly frame, optionally with the poles drawn as well.

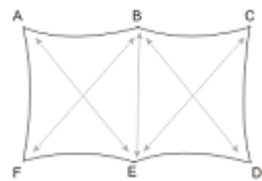

If A, B, C, D, E, F are poles, the most accurate measurements are obtained at the pole tops. This allows for any pole lean or manufacturing errors. Alternatively you can make the measurements at the pole bottoms.

The "Check Measurements" button will confirm that the measurements are consistent, ie that they can produce a valid 6 sided frame. Because we have one more measurement than is strictly necessary we can also report the measurement accuracy.

Example measurements can be imported to show how the tool works.

Draw 4 sided floating frame

In some situations it is not possible to measure the heights of the 4 points A, B, C, D. It is still possible to define a frame that will fit between the points, although the frame will not necessarily be oriented to match the points. So a membrane

designed to fit the frame will also fit the A, B, C, D site points. It is also necessary to define which is the higher of the two diagonals.

The "Check Measurements" button will confirm that the measurements are consistent, ie that they can produce a valid quadrilateral.

Example measurements can be imported to show how the tool works.

Draw XYZ coordinates

Electronic measuring equipment, such as "Total Stations" or GPS survey equipment, can produce a list of X, Y, Z coordinates for the system points. The program can take in a list of these points and will draw a 3d poly frame joining the points.

The coordinates will usually be pasted from the windows clipboard. They can be copied from a spreadsheet, a text document, an email, etc. The program will use any non numeric character as a separator, so tabs, spaces, etc can be used. Optionally the 3d poly can be closed.

Any number of 3d poly frames can be drawn in one go, by separating the point data sets by at least 1 blank line.

Here is an example of a set of coordinates, representing the bottom frame and centre pole of a conic, that can be cut and pasted into the tool options:

```
Base poly
1      519.2511      -24.7030      2.0687
2      512.2049      -20.8973      2.700
3      514.6306      -15.5924      2.500
4      522.7164      -10.4028      2.1742
5      535.3071      -15.5924      0.0000
6      531.2642      -22.1659      1.5940
7      519.2511      -24.7030      2.0687
```

```
Centre pole
1      522.4318      -17.7856      5.3685
2      522.4318      -17.7856      0.0000
```

Smooth machine measured data

Electronic measuring equipment using mechanical, acoustic or laser measuring can produce a polyline trace of existing framework that the fabric needs to fit.

However there is often a "jitter" in the trace polyline caused by operator error / measurement inaccuracies.

This tool takes a slightly jittery polyline and creates a smooth curve through it. The curve can be:

Nurbs curve (spline)
Nurbs curve that lies flat in a plane
Arc

For nurbs curves the number of smoothing points can be set... a lower number gives a smoother curve. Often the ends of the curves must be preserved exactly to meet up with other curves, there is an option for this.

With high frames it is common to trace the underside of the frame, and then need to offset the curve to obtain the fabric touch line. An offset can be specified if the curve lies in a plane or is an arc.

Parametric site library

This tool creates parametric sail site models for re-use in different sizes. As a starting point, clicking on the "Read new site model" button reads a 3D "stick drawing" made from 3dpolys and lines in Cad, and creates a library file that describes the site model. The sticks are designated by their color, and after the model is read in, the colors can be assigned parameter names. The initial parameter values (stick lengths and spacings) are taken from the drawing.

The length of the sticks can be changed by altering the parameter values, and a stick drawing made with these new dimensions by running the tool. In this way, standard site constructions that differ only in their dimensions can be easily created.

The supplied example model is a 4 pole rectangular hyper, where the width, breadth, high pole and low pole heights can be specified parametrically.



Video: [Parametric Site Library](#)

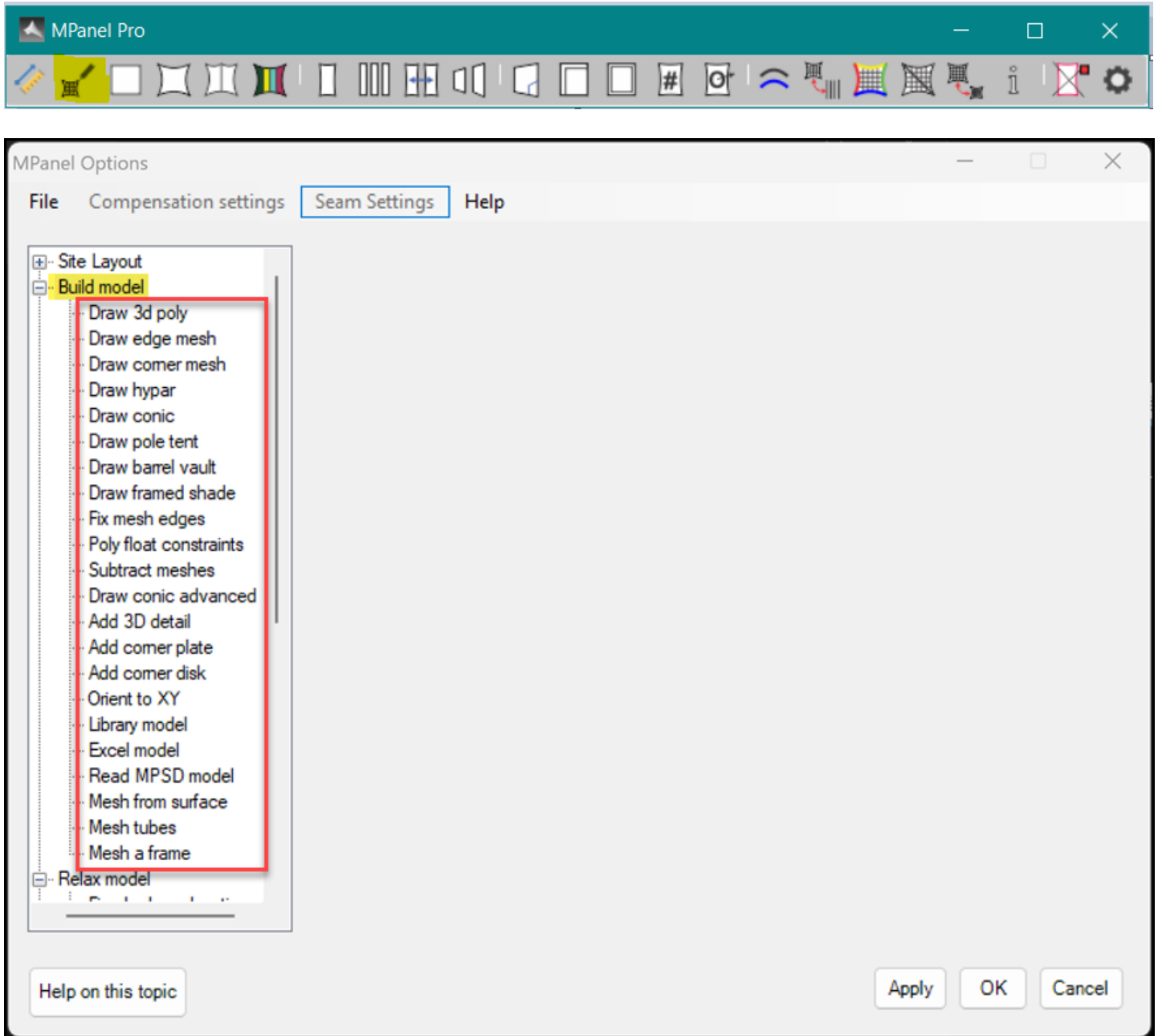

Model Builder is a model building tool that can simplify the drawing of prototype models. The data entry section will vary according to the function selected. It can perform the following functions, as set in the options:

- Draw 3D Polyline
- Draw Edge Mesh
- Draw Corner Mesh
- Draw Hypar
- Draw Conic
- Draw Pole Tent
- Draw Barrel Vault
- Draw Framed Shade
- Fix Mesh Edges
- Poly Float Constraints
- Subtract Meshes
- Draw Advanced Conic
- Add 3D Detail
- Add corner plate
- Add corner disk.
- Orient to XY
- Draw Library model

- Draw Excel model
- Read MPD file
- Mesh from Surface
- Mesh tubes
- Mesh a frame



Video: [Draw Hypar with mixed links](#)

Video: [Draw Conic Advanced](#)

Video: [Fix Mesh Edges](#)

Video: [Framed Shade Structure](#)

Video: [Add Corner Plate](#)

Video: [Orient XY](#)

Video: [Mesh Tubes/Pipes](#)

Draw 3D Polyline

Model Builder will draw a 3D Polyline based on user input points.
 (In AutoCAD this is an encapsulation of the 3D poly command)

Draw Edge Mesh



Video: [Edge mesh filter edges](#)

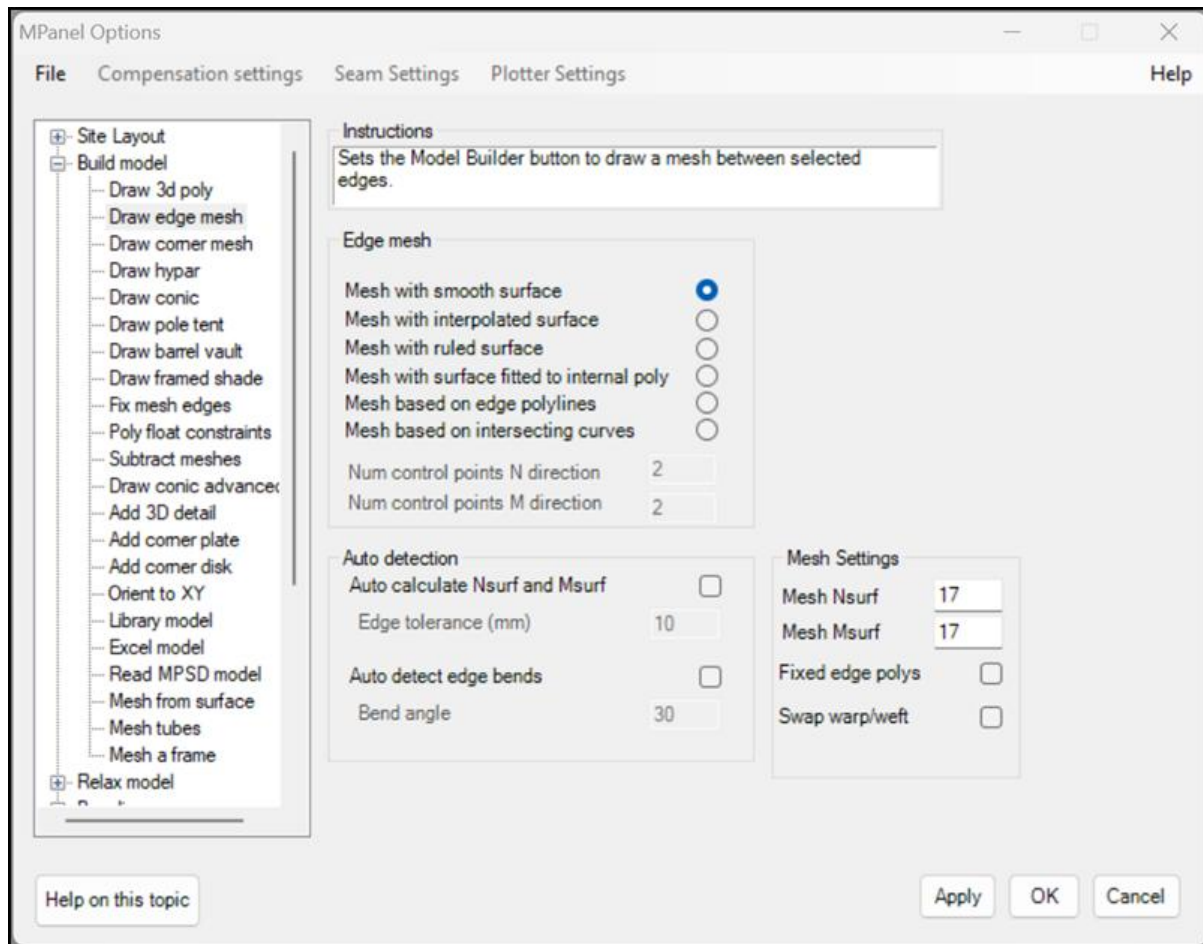

Model Builder will draw a mesh based on four boundary edges, which can be any curve like entities that join together at their ends.

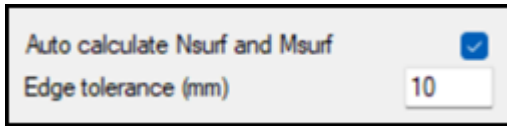

The density of the mesh is set in the options under Nsurf and Msurf or can be **"auto calculated"** based on the specified edge tolerance which defines the maximum distance from the edge to the mesh. The smaller tolerance gap will result in a much higher mesh density.

Auto detect edge bends: if selected, you can specify that sudden bends in the edges are detected and have a mesh node on them. They are detected by the bend angle, the default value is 30 degrees.

The edge first chosen (MPanel Pro prompts to select Bottom first) defines the weft direction of the mesh, so the warp direction runs away from that edge. From version 25 on, a new feature was added to MPanel Pro to ignore meshes and text inside the CAD pick box area and only select curves/polylines to speed up adding meshes. In AutoCAD "Selection Cycling" must be turned off for this feature to work.

- Mesh with smooth surface

To draw a mesh based on 4 boundary edges select the edges as prompted in the CAD text window

To draw a mesh based on three boundary edges, skip the top edge when selecting the edges, by using the Enter key

To draw a mesh based on two boundary edges, skip the left and right edges when selecting the edges, by using the Enter key

- Mesh with interpolated surface

In some applications a less smooth, more interpolated mesh is preferable

- Mesh with ruled surface

In some applications such as marine windscreens a mesh using a ruled surface can be used to make a single panel with lower shear strain values than traditional meshes.

- Mesh with surface fitted to internal poly

This fits a mesh exactly to 4 edges, and smoothly through another poly called the surface poly (or scribble poly) with defines some internal points.

This can be used when the four edges of a surface have been traced with a mechanical digitiser, and then the surface shape has been mechanically traced as well.

The fitted surface is a B spline surface defined by a specified number of control points.

The smaller the number of control points the smoother the surface will be, with more control points the surface will follow the internal points more closely.

Often just 2 control points in the N and M directions are sufficient.

- Mesh based on edge polylines

This draws a mesh between 3d polyline boundaries with the mesh edge nodes exactly the same as the 3d polyline.

This allows modeling a mesh on a boundary that contains corners.

A consequence of this method is that the mesh nsurf and msurf are determined by the 3dpoly node count and also that the top/bottom and left/right polys must each have the same number of nodes;

- Mesh between intersecting curves

This works in a similar manner to drawing a mesh based on 2, 3 or 4 edges, but the edges only need to intersect on the same plane thereby reducing the time required to split lines/curves to use the previous tool. Like the previous tool, you can choose the number of points used to build the mesh or you can select the "Auto number of points" option to simplify mesh building.

There is an option to draw a 3d poly along each mesh edge to fix the edges during relaxation.

Any 3dpolys not needed (cable edges) can then be deleted.

Normally the edges defining a mesh should join exactly at the corners.

If there is a small gap the program will offer to "ignore" the gap and continue building the mesh.

The user must then inspect the mesh to see if the corner error is acceptable.

Draw Corner Mesh

Model Builder will draw a mesh based on four corners specified as user input points in the drawing. The CAD text window

will prompt for the corners in order. The mesh is drawn such that the first two points define the weft direction and the warp direction runs away from those points. The density of the mesh is set in the options under Nsurf and Msurf. If panels were produced directly from the mesh then Msurf is one more than the number of panels in the mesh, and Nsurf is the number of points on the edge of each panel.

A square mesh of specified base width can be drawn by using the "Enter" key when prompted for the second user input point.

A triangular mesh can be drawn by using the "Enter" key when prompted for the fourth user input point.

Draw Hypar (Sail Tent)

Model Builder will draw a flat sail as a mesh with system points on a 3D polyline between four corners specified as user input points in the drawing. The CAD text window will prompt for the corners in order. In addition a link representing a corner guy can be included at each corner. The corner link can simulate a hardware fitting like a D ring or EZ glide, or a corner plate. [See here](#) for a description of links that simulate the corner hardware.

A square mesh of specified base width can be drawn by using the "Enter" key when prompted for the second user input point.

A triangular mesh can be drawn by using the "Enter" key when prompted for the fourth user input point.

The option "corner links" will add a link to each corner. The link can represent a guy line, or can simulate end width. Links that simulate end width are [described here](#).

Draw Conic (Cone Tent)

Model Builder will draw a conic with several meshes, a top ring and system points. The model is defined by option parameters including Base width, Ring diameter, and Model height. The model is drawn in at a user defined insertion point, with even dimensions all around. The system points and mesh corners can then be dragged or stretched to suit the model requirements that you have.

The option Swap Warp/Weft will draw the mesh with the warp and weft directions swapped.

The option "With fixed Edges" will draw in a series of 3DPolys for the fixed edges, and snap the mesh edges to them.

The option "Corner links" will add a link to each corner. The link can represent a guy line, or can simulate end width. Links that simulate end width are [described here](#).

The option "Make bottom circular" will force the bottom edge into a circle with fixed edges.



Video: [Conic with circular base](#)

Sometimes you will need to create several prototype models to add together in a modular fashion to make your model. To adjust the prototype system points to suit your model, select the meshes and the system point line and drag the corner nodes to their new location.

(In AutoCAD, you can use the Stretch command to move the top ring and mesh attachments all at once, or you can select the nodes you want to move)

(In Rhino, you can turn the control points on and then select all the points you want to move)

Draw Pole Tent

Model Builder will draw a pole tent with several meshes and system points. The model is defined by option parameters including Base width, Number of meshes, and Top elevation. The model is drawn in at a user defined insertion point, with even dimensions all around. The system points and mesh corners can then be dragged or stretched to suit the model requirements that you have. The option Swap Warp/Weft will draw the mesh with the warp and weft directions swapped. The option "With fixed Edges" will draw in a series of 3dPolys for the fixed edges, and snap the mesh edges to them.

Draw Barrel Vault

Model Builder will draw a barrel vault structure based on entered parameters. Once the model is built meshes can be re-drawn to include both keder track offsets as well as tensioning allowances at the arch ends. The options are as follows:

Build barrel vault - will build meshes and 3D polys in the shape of arcs along with poles as specified in the Main Parameters

Build barrel vault with production offsets - same as above with optional adjustments to account for:

- keder track at the as an offset from the end (outermost) arch centre lines
- keder track at the as an offset from the internal arch centre lines (aka double rope track)
- arch end trim lengths to allow for tensioning devices (such as toggle bolts etc)
- trim end arch offset to adjust for the catenary cable angle to terminate on the arch centre line which varies with dip/span ratio [more information](#)

Apply production offsets to existing arches - applies any of the options described above to an existing set of arches (3D polylines in the shape of arches) providing these time saving tools to be used with your own custom designs.

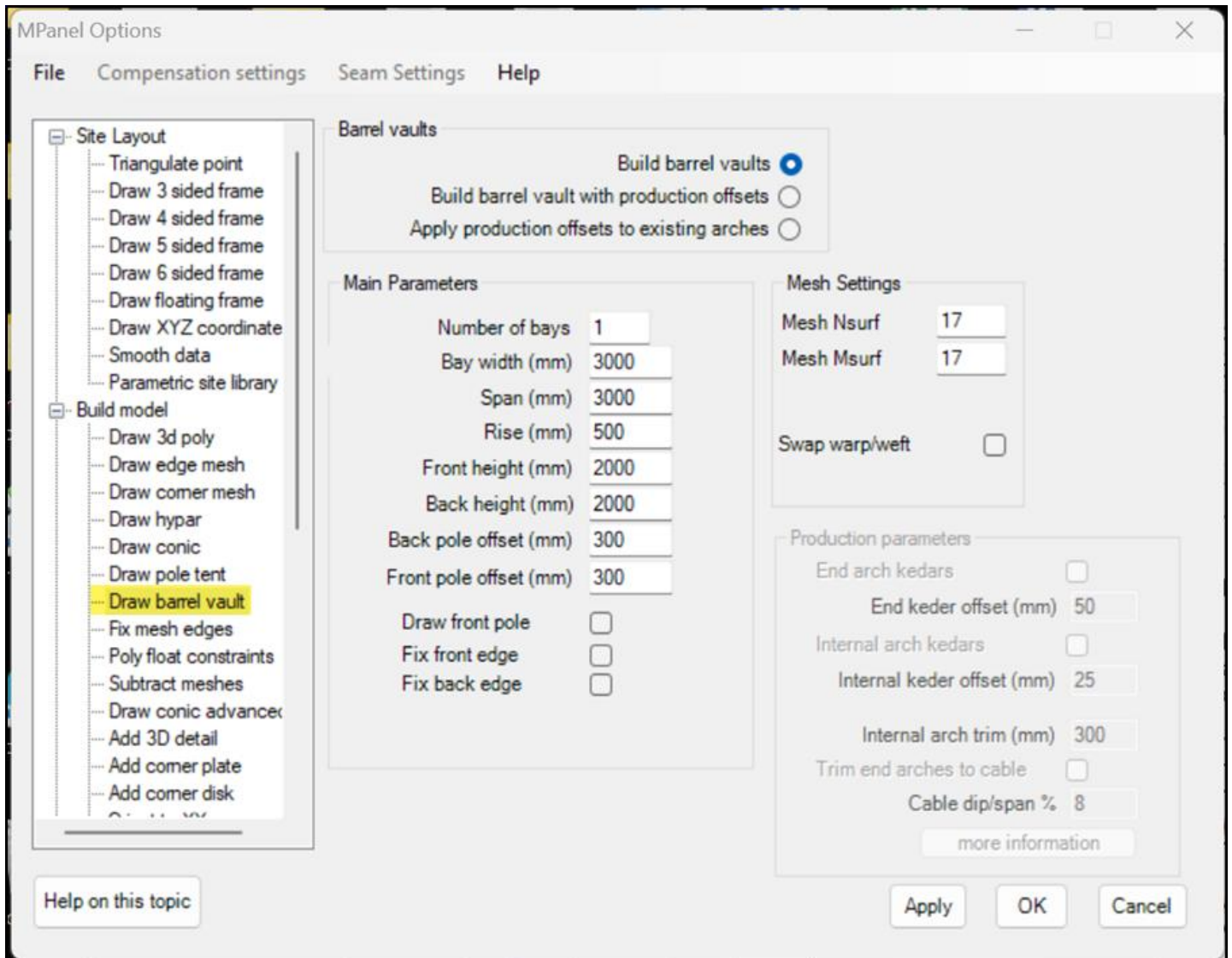

Video: [Drawn barrel vault](#)

Draw Framed Shade Structure

Model Builder will build a framed shade structure (FSS) based on the entered parameter. Once built, the whole model can be selected and relaxed as a cable edge mesh



Video: [Parametric Framed Shade Structure](#)

Fix Mesh Edges

Model Builder takes some meshes and 3Dpolys, and "fixes" the edges of the meshes to the 3Dpolys. There are 3 sub programs, which use the following rules:

Fix mesh edges in straight line between poly nodes. (used to fix mesh edges in straight lines)
If some mesh nodes are snapped to adjacent poly nodes (often the mesh nodes are the corners)
a new poly is drawn straight between the poly nodes with the same number of points as the mesh edge gap
and the mesh edge nodes are snapped to the poly nodes.
(note that in Rhino a poly must have at least 3 nodes)

Snap mesh edges nodes to existing poly (used to fix mesh edges to a curved poly)
If some mesh nodes are snapped to some poly nodes
and the number of nodes "in the gap" equals the number of poly nodes "in the gap"
the mesh nodes "in the gap" are snapped to the poly nodes "in the gap"
(the mesh nodes do not have to be corner nodes)

Snap mesh edge nodes from existing poly to new poly (used to change mesh edges, like moving a conic top ring)
If mesh edges are fixed to an existing polyline
and a new polyline is also selected that is not connected to the meshes, and has the same number of nodes
the mesh edges will be moved to the new polyline

Poly Float Constraints

Model builder can add a tag to 3D polylines to specify special handling during relaxation. The special handling allows 3D polys, to move in some restricted manner during relaxation, to achieve a force balance. The possible settings are:

Check	Reports on any existing tags
None	Sets the tags to no special handling
XY	Allows the 3D poly to move in the XY plane
Z	Allows the 3D poly to move in the Z axis
Rot X	Allows the 3D poly to rotate around the X axis
Rot Y	Allows the 3D poly to rotate around the Y axis
Rot	Allows the 3D poly to rotate around the Z axis
Rot XYZ	Allows the 3D poly to rotate in all axis, may cause instability
Sxy	Constrains the 3d poly to be straight when viewed in top view
Sxz	Constrains the 3d poly to be straight when viewed in front view
Syz	Constrains the 3d poly to be straight when viewed in left view
EcPole	Simulates an encastre pole by specifying a top spring with a rate to suit the supplied parameters
Lean	Instructs the pole to lean by a specified angle away from the pole top force during relaxation
Syz	Defines the ends of cables, helps MPanel Pro calculate the cable tensions in complicated models



Video: [Pole Lean](#)

Video: [Syx - define cable ends](#)

Subtract Meshes

Model builder will take two meshes, and try to interpret one mesh as a hole in the other. If this is possible then a series of meshes will be drawn around the hole, that can be used as joined edge meshes during relaxation. Only the corners of the smaller mesh are checked, and they should be snapped to the vertices of the larger mesh.

This function can be used to develop hyper sails with holes in them, or doorways in wall structures.

Draw Advanced Conic

Model Builder will take a circle representing the top ring, and a 3D polyline representing the base, and will draw in meshes between the two, with the mesh Msurf being varied on each mesh to achieve an equal mesh thread spacing on the 3d Poly. This can make a better model when the base width varies a lot. The average msurf is set in the options. The circle can be angled to any plane, and will be overdrawn with a 3d polys. The option "With fixed Edges" will draw in a series of 3dPolys for the fixed edges, and snap the mesh edges to them. The Draw advanced conic tool supports building multiple conics at the same time and ensures the mesh msurf is the same for all joining meshes.



Video: [Conic Advanced](#)

Add 3D Detail

The main use for this tool is to assist in designing corner plates to terminate fabric corners and cables.

This tool will read a flat dxf detail drawing from a library, and insert it between two reference lines in the 3d drawing. The drawing reference lines are colored green and blue, and the lines must touch at one end, so they form a V. The V can be in any xyz plane.

Alternatively the dxf detail can be inserted between mesh edges, where the mesh corner is identified by a short Cyan line, or by nodes on a 3d polyline.

The dxf drawing consists of 2d polylines that will be transferred to the 3D drawing, a dxf reference V in green and blue, and optionally some points. Entities in the dxf drawing can have special meaning depending on their color or layer. This is described in the [detail dxf specification](#).

Some simple detail drawings are included during installation. You can use these as a starting point to draw your own dxf detail drawings.

Angular scaling can be:

to fit between the drawing V lines.

to fit in a mesh corner

to fit in a mesh corner tangentially, ie allowing for the curvature of the mesh edges

Linear scaling can be:

to fit the average length of the drawing V lines or cyan line

to scale to a specified length

The scaled and oriented detail is drawn out as 3Dpolys, and optionally some points.

The 3Dpolys are the main entities in the inserted drawing, and are used to define the basic reinforcement plate shape.

The optional points can be used to carry position information into the paneling process.

Add Corner Plate

Adds corner detail, including a clamp plate with spaced bolt holes, cable tubes, fabric reinforcement patches and seam cutouts for the cable termination. These are dimensioned from the front edge of the clamp plate, so varying the plate size varies all the dimensions parametrically.

The corner plate is usually inserted at a mesh corner, marked with a cyan line, or with the nodes of a 3d polyline. The insertion can be angularly scaled to fit the mesh corner. The effective "plate arc centre" can be at the mesh corner, or at a position defined by a tangents the mesh edge at the insertion point.

The corner plate is drawn as 3dpolys, which have tags in the extended data to define them as corner detail during the paneling process.

V30 adds an estimated reaction angle line to the reinforcement patch - see video linked below:



Video: [Corner reinforcement patches with estimated reaction force angle](#)

Cable lengths including corner cable corrections are provided in physical model report. Cable lengths are adjusted by reducing the total edge length by the distance from the outside of the cable tube to the corner. If the cable tube length is longer than the clamp plate width this extra length will need to be added to both ends of the cable to achieve the correct cable dimension defined by mid thread to mid thread of the studs (see below).

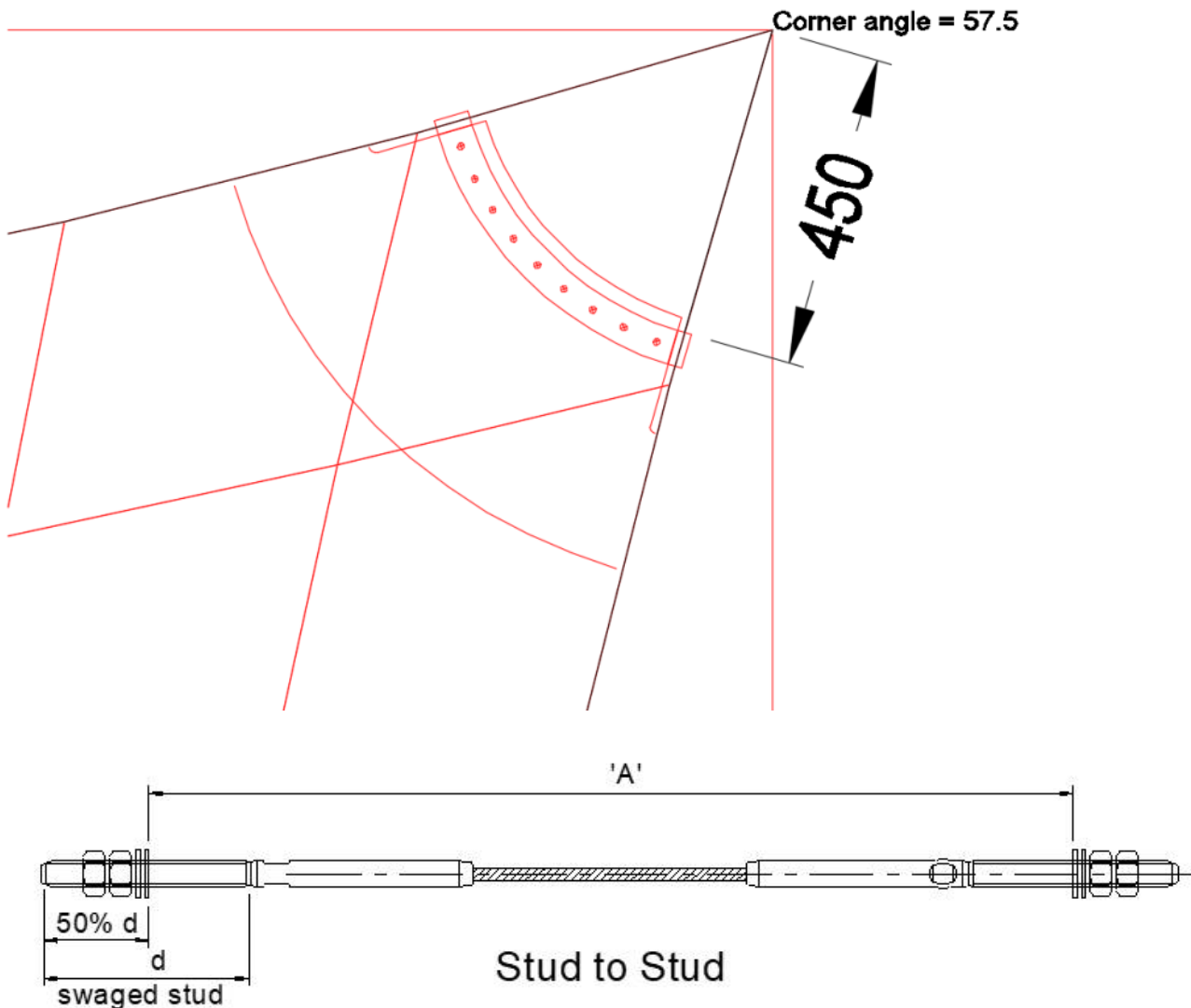



Video: [Adjusted Cable Lengths](#)

Add Corner Disk

Adds corner detail, including a disk with spaced bolt holes, fabric reinforcement patches and seam cutouts for the cable termination. These are dimensioned from the front edge of the clamp plate, so varying the plate size varies all the dimensions parametrically.

The distance of the disk from the mesh corner is adjusted to make the disk tangential to the mesh edges.

The corner disk is usually inserted at a mesh corner, marked with a cyan line, or with the nodes of a 3d polyline.

The corner disk is drawn as 3dpolys, which have tags in the extended data to define them as corner detail during the paneling process.

Cable lengths including corner cable corrections are provided in physical model report. Cable lengths are adjusted by reducing the total edge length by the distance from the outside of the clamp plate (the plate radius) to the corner. The user needs to add the cable tube length at both ends of the cable to this dimension.



Video: [Adjusted Cable Lengths](#)

Orient to XY

This tool helps to orient meshes so that they are most fully visible in Top view to facilitate the creation of cross sections. The options are:

Orient each mesh with XY plane in the mesh

This orients each mesh, and any points to be as flat as possible in the XY plane

Orient each mesh with XY plane and space apart in the mesh

This orients each mesh, and any points to be as flat as possible in the XY plane and then spreads the meshes apart

radially until they do not overlap

Orient entire model with XY plane lines and any points in the mesh

This orients each mesh, with 3dpolys, to be as flat as possible in the XY plane A principle use of this tool is to take

3D corner plate detail and lay it flat for a metal work drawing.

The if the original objects lie in a plane, then the orient to XY will produce a perfectly flat 2D drawing.

If the original objects do not lie in a plane, then a "best fit" plane will be used, getting the oriented objects as flat as possible. This can be used for re orienting a mesh model that is largely vertical for cross sectioning.



Video: [Orient XY](#)

Draw Library Model

[Described here](#)

Draw Excel Model

[Described here](#)

Read MPSD file

This tool will read an MPanel Pro Shade Designer file (*.mpm) and build the prototype model described in the file. This allows users who obtain their site measurements with MPSD to build the model with MPanel, which gives more design and paneling options. The meshes will have extended data set for weft/warp stress ratio's and cable tension, so if you want to alter the model with the MPanel Pro options you will have to set the extended data back to the default setting, as [described here](#)

If the mpm file was a partial file (produced by the MPSD site checker web site) then the prototype model will be drawn with no extended data and no corner links.

Mesh from Surface

This tool will take a simple surface, and try to convert to a regular polygon mesh that can be used by MPanel. If the surface has 3 or 4 edges then the surface edges can be used directly. For more complicated surfaces the 3 or 4 edges will have to be drawn on the surface before using this tool.

Mesh tubes

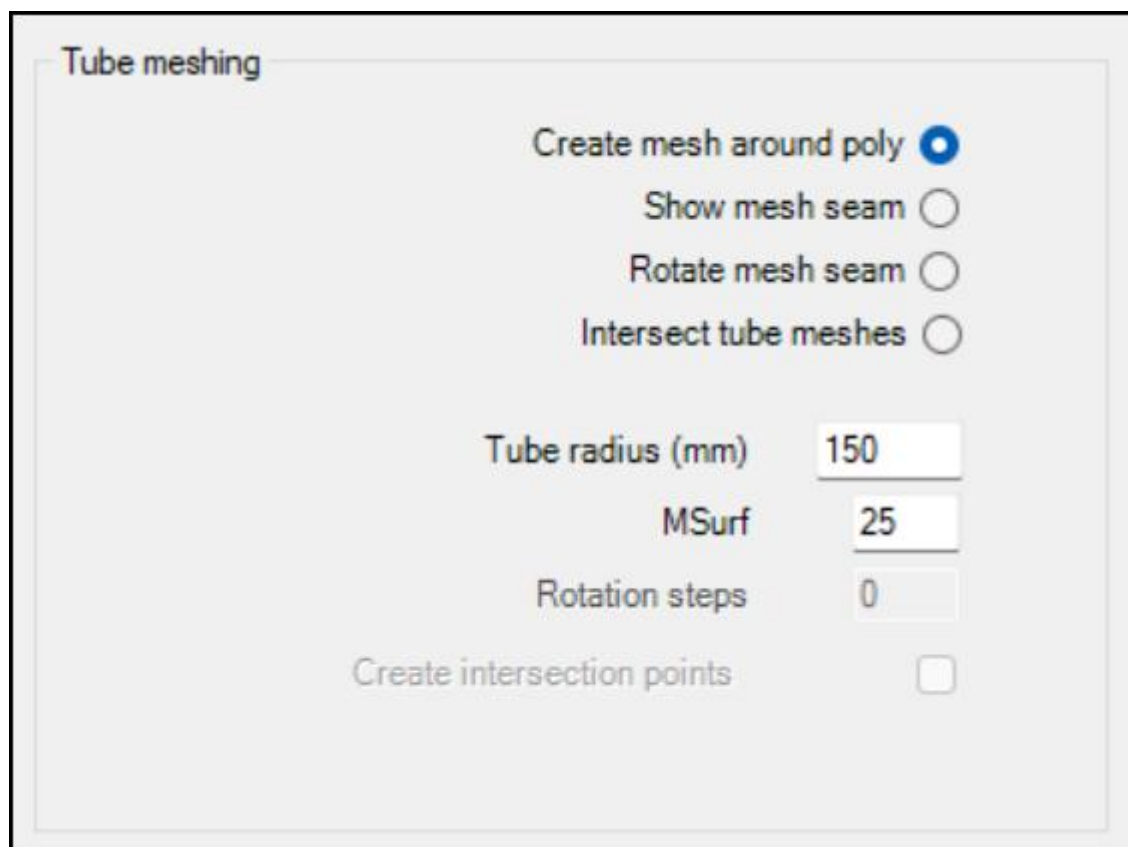

Tube meshing

Create mesh around poly

Show mesh seam

Rotate mesh seam

Intersect tube meshes

Tube radius (mm)

MSurf

Rotation steps

Create intersection points

This tool will add tubular shaped meshes to one or more 3D poly lines which is useful for inflated tube structures for example or for fabric covers used as insulation/lagging over pipes etc.

Workflows:

- Define the desired tube radius and mSurf.
- Select one or more 3Dpoly lines,
- Run tool with Create Mesh tool checked to add meshes
- To intersect tubes select the meshes and run the tool with "intersect tube meshes" option checked. This will change the shape at the ends of the intersecting tubes. Create intersecting points will add points to the mesh models which can be used to add detail during panelling.
- To show mesh seam - make copy of meshes and run tool - delete old to show default seam location which is nominally at the bottom of the tube.
- Rotate mesh seam will move the seam clockwise (with respect to poly drawn direction) the number of MSurf steps defined by Rotation steps.

Refer also to [Split mesh into segments](#)



Video: [Mesh Tubes/Pipes](#)

Mesh a Frame

This tool will automate the meshing of simple frames made up of lines, polylines, curves and/or splines. The tool may add multiple unwanted meshes where a continuous outer frame exists - these meshes can be deleted afterward or the boundary polylines can be broken to avoid the extra mesh. Meshing of complex frame geometry (especially where there are errors such as elements not connecting in corners for example) may not produce all the meshes requiring manual mesh addition for a small percentage of the model.

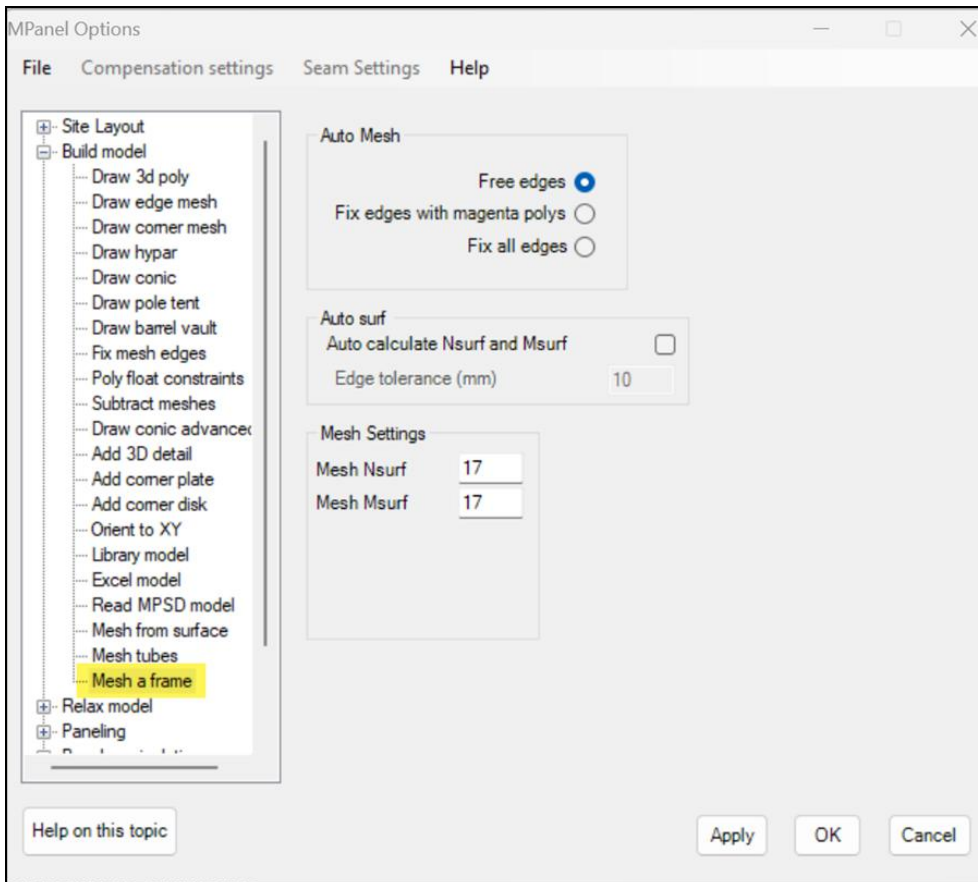

Video: [Mesh a frame](#)

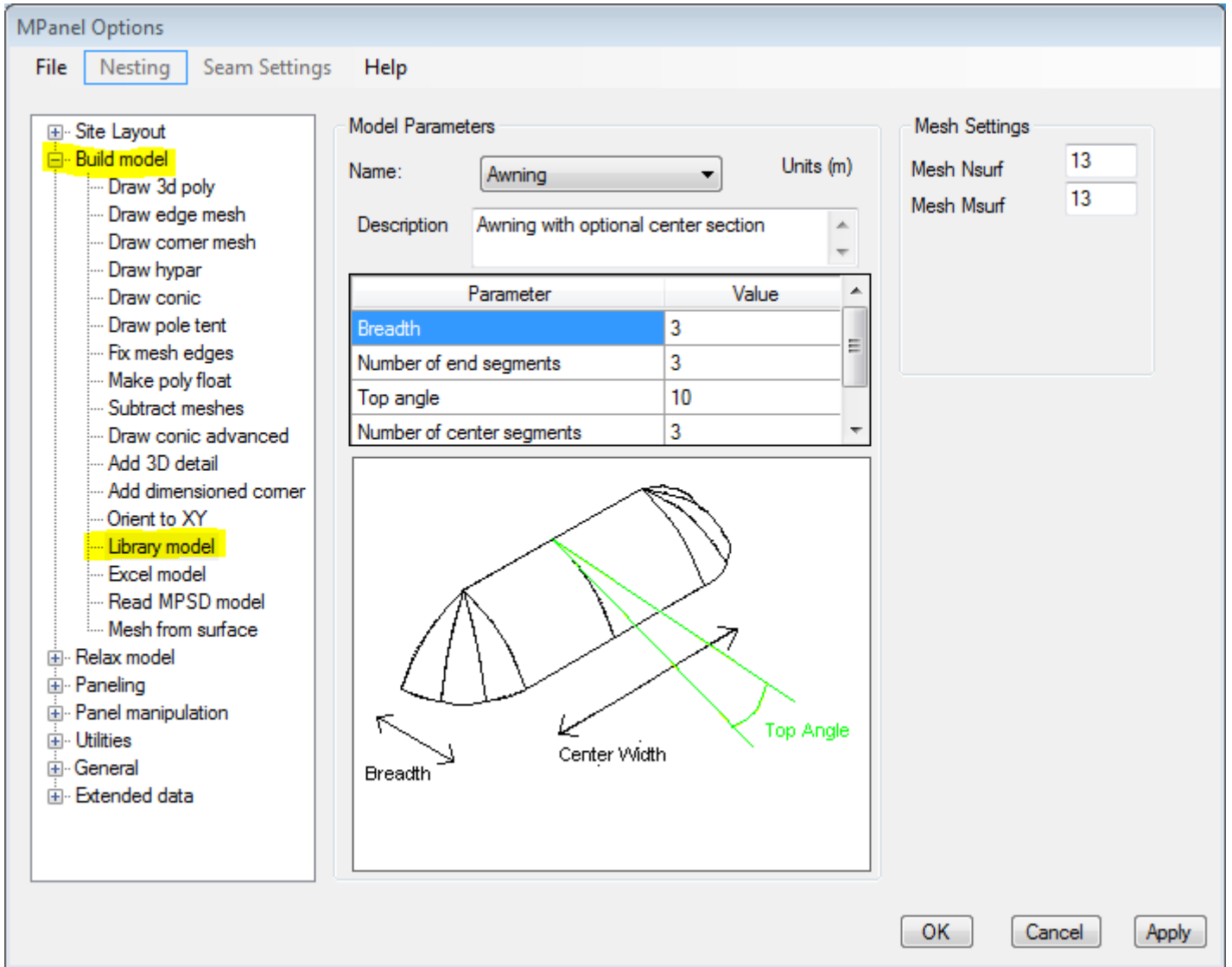

Model builder will draw a model with meshes and 3dpolys defined in a library of standard designs. The required model is selected from a drop down list, and will be drawn out when the Model Builder button on the toolbar is clicked. Library models include:

- Awnings
- Barrel vaults
- Pole tents with valances
- Cable supported tents
- Modular cone tents
- Hypar sails
- Framed shade sails



Video: [Framed Shade Structure](#)

N.B. When panelling framed shade structures ensure the panel orientation tool is set to "warp mesh aligned" to ensure panels are drawn in the correct orientation.

To build a Library model:

- In the MPanel Pro Options specify the Model Builder to use Library models
- Choose the model you want from the drop down list.

- Change any parameters you need to suit your dimensions.
- Close the options and use the Model Builder button to create the model.

You can make your own copy of a library model template, by using the "Library Model.... Save as" tool on the File menu. This lets you build up a library of your own models, perhaps for company standard designs.

A description of the basic model templates is available here: [Library](#)
Other models may be added later.

Excel Models

Excel spreadsheets are supplied for all the library models, and can be used instead of the model library to define models.

The spreadsheets will be in your Documents/MPanel/Excel folder.

To use a spreadsheet for a design:

- Open the spreadsheet in Excel.
- Make any changes needed to the parameters.
- In the MPanel Pro Options specify the Model Builder to use Excel models.
- Run the model builder to create the model.

An advantage of using spreadsheets as the design input is that the parameters can be calculated from a formula. So you might be making a range of tents, with the pole height determined by a formula involving width, breadth, or other factors.

To be read correctly, the spreadsheet has to follow the following rules:

- The spreadsheet must be open in the first running copy of Excel.
- Cell A1 must contain the text: **MPanel Pro Design Sheet**
- The parameter names must be in column A
- The parameter values must be in column B

Relax Mesh

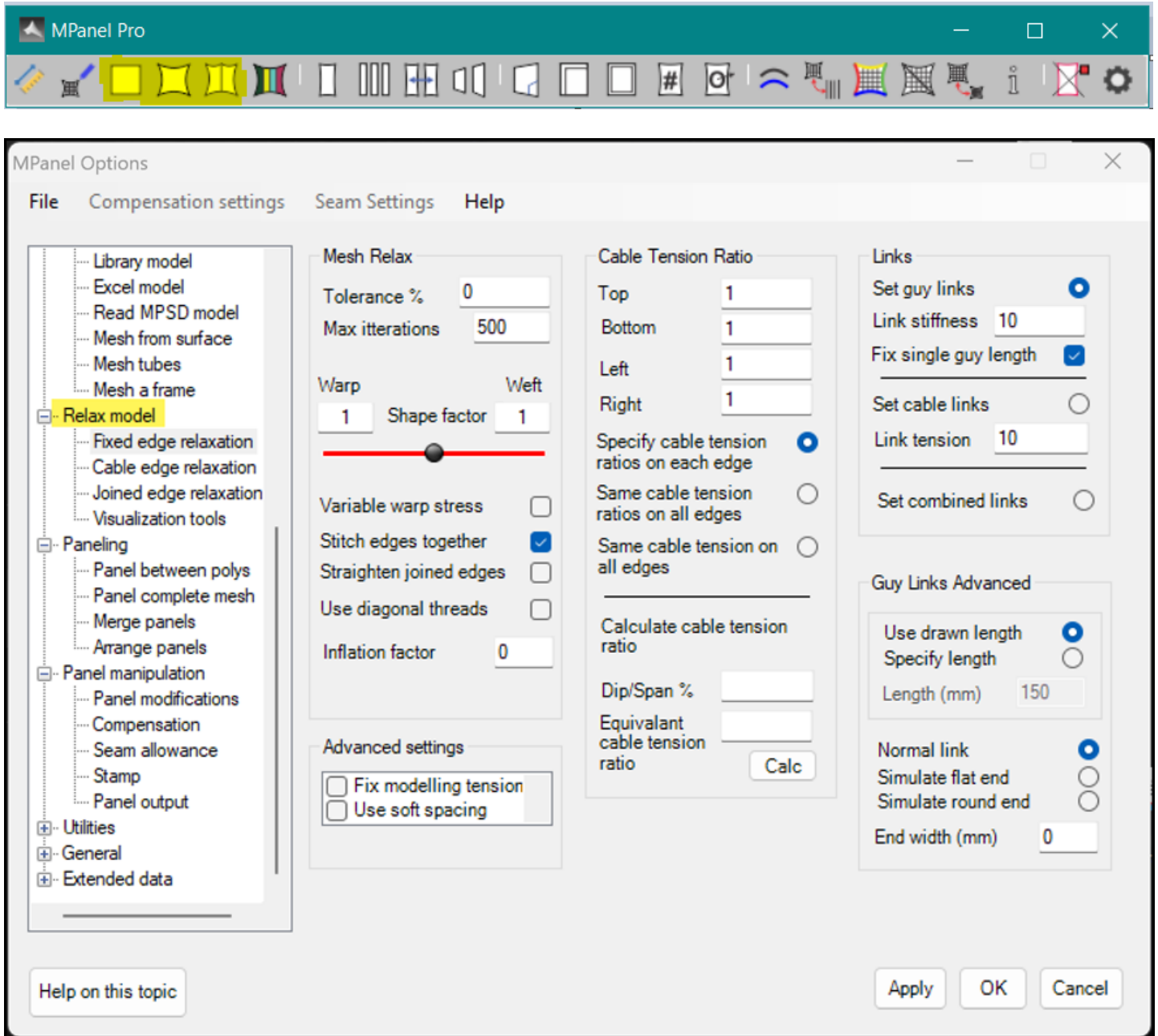

The three mesh relaxation tools can be used to relax one or several meshes, with the following boundary conditions:

- Fixed edge meshes: all mesh edges are fixed. Additional fixed points can be specified using 3D poly nodes.
- Cable edge meshes: all mesh edges contain cables. On edges with corners that join onto another mesh edge, with the same number of nodes on each, the edge nodes are usually stitched together with the option "Stitch edges together". Fixed points must be specified using 3D poly nodes.
- Joined edge meshes: if a mesh's corners are joined to another meshes edge, with the same number of nodes on each, then those edges are treated as a smooth joined edge. The nodes between the corners will be stitched together automatically. All other mesh edges contain cables. Fixed points must be specified using 3D poly nodes. Joined edge seams can be forced to appear straight when viewed from above with the option "Straighten joined edges".

Additionally links can be used to restrain the movement of points in the mesh relative to other points. See [Using Links](#) for more information on this.

To relax the model, select all the meshes, 3Dpolys and links in the model, and click on the appropriate relaxation button.

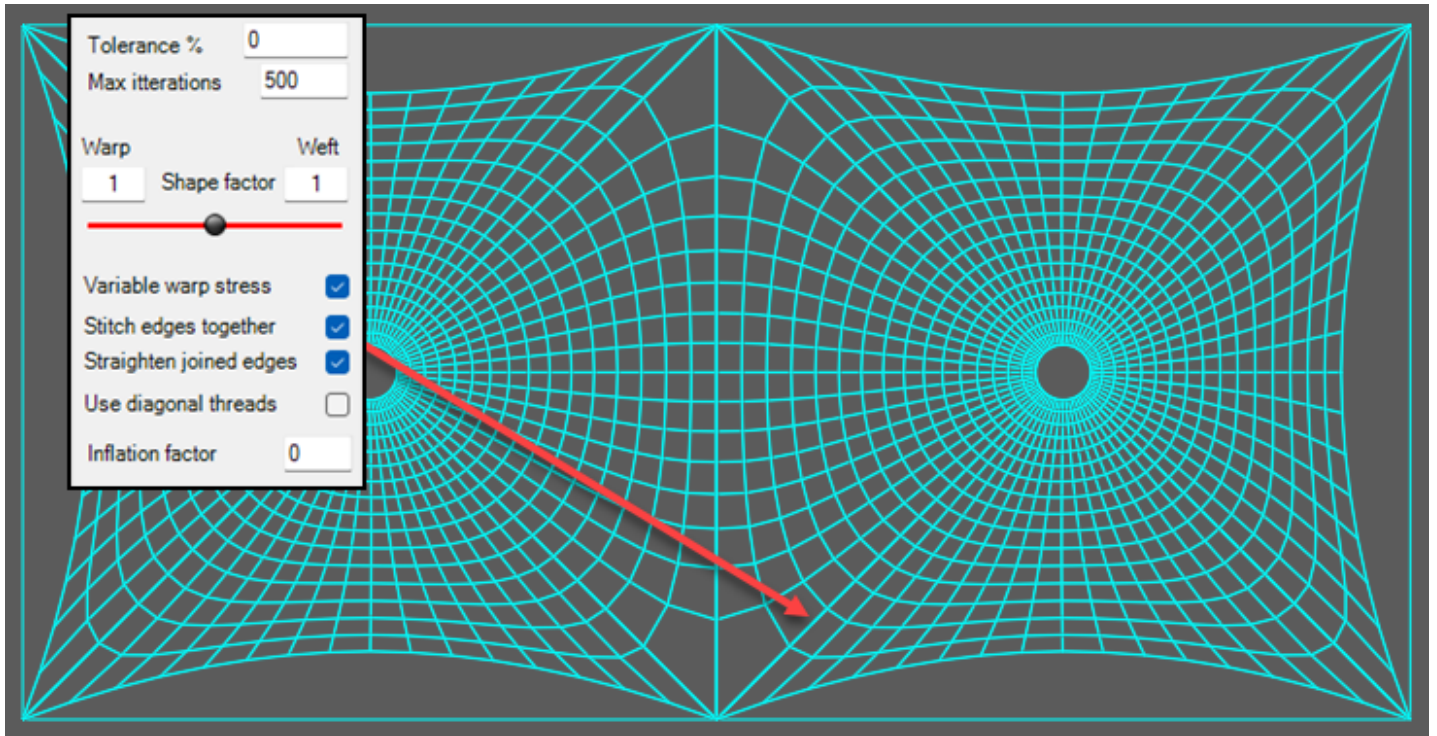
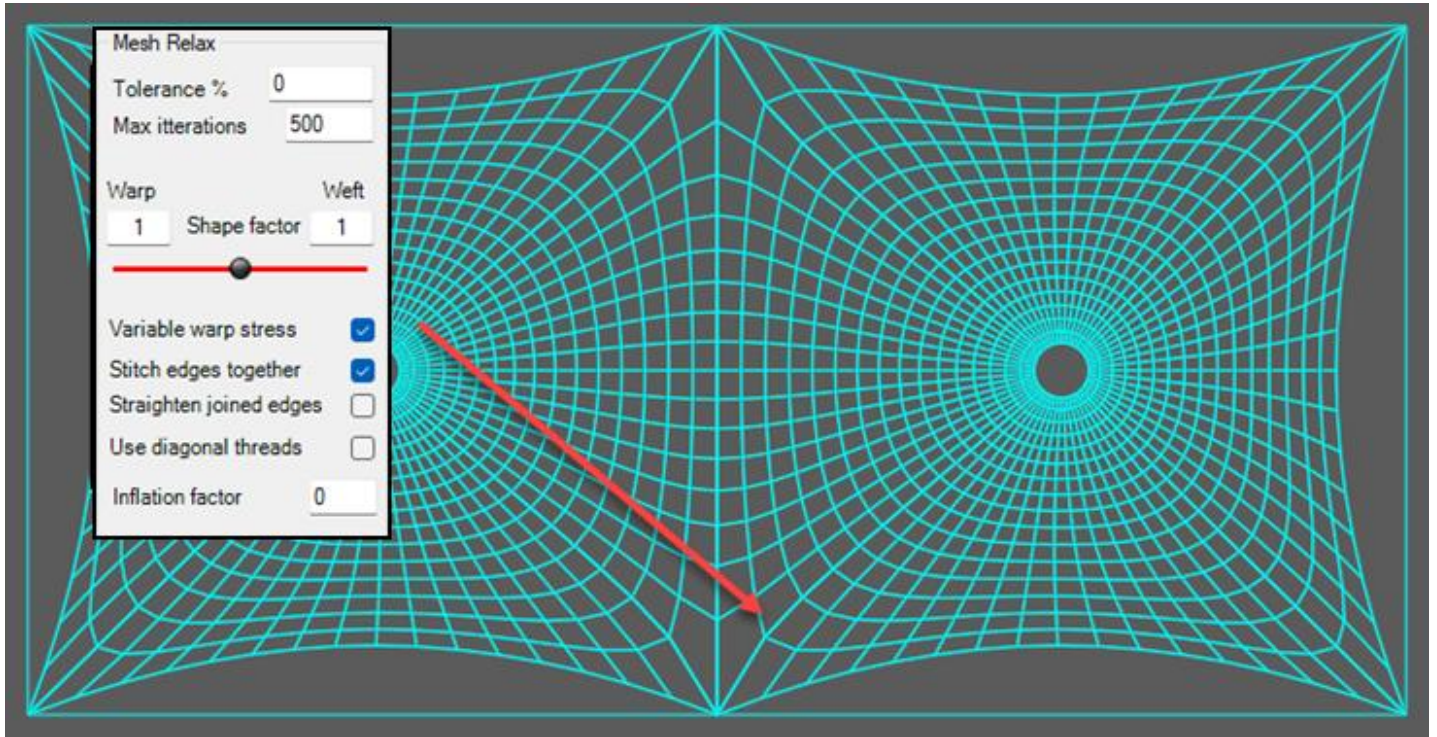

Relaxation method

The mesh is relaxed towards a shape that has an even stress across the mesh surface, using a "Constant stress algorithm" (CSA). On a simple shape this will be an approximation of a soap bubble surface.

In some cases, notably conics with small top rings, the constant stress surface is not visually appealing. In these situations you can increase the stress in the parts of the mesh where the mesh warp threads are closest, ie around the top ring, by selecting "**Variable warp stress**"

The shape of the surface is controlled by the "**Shape Factor**" which changes the stress in the warp and weft directions. The slider moved to the left will increase the stress in the warp threads while the weft threads remain at the default stress of 1. The reverse applies if the slider is moved to the right of the default center position. This stress ratio can be set to achieve a variety of different anticlastic shapes. The slider is limited to stress ratios of 1:3 or 3:1 which is typically the maximum stress ratio for most fabrics for general purposes. Larger values can be used by manually entering values above the number 3 e.g. 10 will result in a stress ratio of 10:1 (or 1:10). If ratios substantially different from 1 are used, caution is required to ensure that your fabric can physically take the stress ratio selected.

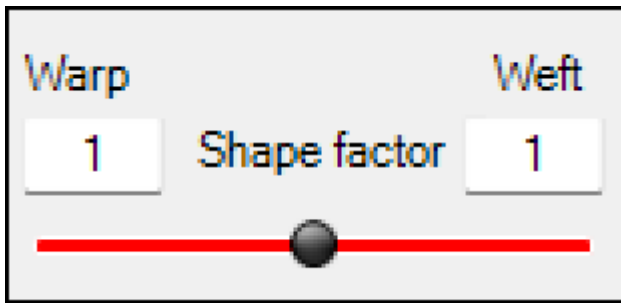

Video: [Shape Factor Tool](#)
(MediaSlider v1.3 by John Underhill)

During relaxation a Cancel button is shown in the MPanel Pro text window. The relaxation can be interrupted with the cancel button (or by the ESC key when MPanel Pro has the focus) an option to draw out the partially relaxed mesh will be offered. This may be acceptable if the reported residual was low enough.

Technical descriptions of the relaxation methods used are here: [CSA method](#)



Video: [Controlling shape of Conics](#)

To check that the mesh is fully relaxed



The number of iterations needed to fully relax a model depends on the geometry, the mesh density and the number of meshes.

To check if the mesh is fully relaxed you can check the residual mesh movement, reported on the MPanel Pro toolbar during the relaxation, and in the MPanel Pro text window afterwards. Or look at the old and new meshes after a fixed number of iterations and see if there is any shape change.

The residual represents the average percentage movement of the mesh during the last few iterations, less than 0.0001 usually indicates a converged mesh.

Mesh direction

The direction from the bottom of the mesh to the top is called the mesh warp direction, on the assumption that panels will be built in this direction. The direction across the mesh is called the mesh weft direction. To find the warp direction on a mesh that is already drawn use the [Information](#) button.

Lofting

Optionally the internal model can have additional diagonal threads across the mesh cells. The tension in these threads is controlled by the weft/warp stress ratio, so this allows us to adjust the droop of hypar sails.

Cable names and shaping

The cable tension for the four mesh edges can be individually set in the options screen. "Cable tension bottom" refers to the cable tension on the bottom of the meshes, which may not be at the bottom of the screen. A cable tension of 1 means a tension in the cable equal to the total tension in the fabric on that edge, and will roughly make a cable arc with a radius the same as the mesh edge span (includes any corner links). This method means that longer spans tend to get assigned more internal modeling tension, which is usually what is wanted to keep the cable edges a reasonable shape.

Optionally "Same cable tension ratios on all sides" can be specified. This will give approximately the same dip/span ratio on all the cables.

Optionally "Same cable tension on all sides" can be selected. This calculates the internal modeling tension based on the average edge length, so gives the same cable tension on each side. This should always be used when the cable edges pass through the corner, ie when you need even cable tensions on all edges.

Often cable edges are specified by the "Dip/Span" ratio. A calculator is provided to convert dip/span ratios into the equivalent cable tension. This calculation will only apply to cables that span one entire mesh edge. The calculator is reasonably accurate for commonly used dip/span ratios (5% to 20%) becoming less accurate at larger dip span ratios.



Video: [Cable tension ratio](#)

Guys and Cables

Lines in the drawing will be read as either links simulating guys or links simulating cable segments, depending on the setting in the options. They can be used for corner link (turnbuckle etc.), simulate corner plates or hardware, and to create cables in the mesh. A fuller description of using links is [given here](#).



Video: [Diagonal Cables](#)

Extended data

When the model is relaxed, mesh relaxation parameters are saved as extended data. This information can be inspected in the Extended data tab, and can be altered for individual meshes.

On the next relaxation any extended data will be read in, and this allows you to alter the parameters of individual meshes or just a section of the model.

Poly Float constraints

Normally a 3D poly defines a series of fixed points. But a polyline can also have a tag placed on it to make it behave differently during the relaxation. The tags are placed on using the Model Builder "Float Polys" tool. The tags can allow the polyline, as a whole, to:

- Move in XY (finds the conic top ring force balance position for vertical poles)
- Move in Z
- Rotate around the X, Y or Z axis (finds the conic top ring balance angle for angled poles)
- Constrain points to be in straight line (to make a tent lace lines, or straighten a valley)

- seam)
- Simulate Cantilever Pole (define pole size and fabric prestress to show pole top deflection)
- Add pole lean angle (angle defined in options)
- Define cable ends (helps MPanel Pro determine cable tensions in complex multi-sail models)
- Check constraints (reports on the current poly tags)

Using these options it is possible to find the force balance position for vertical pole supported tents, the pole angle for asymmetric tents, of the position of a free floating stiff member, such as a centre ring, or constrain part of the mesh to lie in a straight line, such as for a tent lace line. The tag can be written to the poly with the "Set float" button in the options, or by closing the options and running the model builder Float poly tool.



Video: [Define cable ends float poly](#)

Other relaxation options

Optionally the tension in each thread can be adjusted toward a constant fabric stress over the mesh. This can be of use in evening out stress variations, but may produce less pleasing shapes. When using constant stress, it is better to apply several small relaxations, to allow the tension matrix to be updated.

Optionally you can fix the guy length. If there are links in the model used as guys, they will stretch some during the relaxation process. Best practice is to let them stretch and use the finished link length as your guy specification, but you can force a fixed length onto single guys that are anchored at one end.

Optionally, a pressure can be applied across the mesh. This will result in a inflated shape. Depending on the geometry pressure settings from 0 to 1 will give reasonable inflated shapes. When using pressure, it is better to apply several small relaxations, to allow the tension matrix to be updated.

Optionally the legacy relaxation method can be used to replicate a model made before version 17.

Advanced relaxation options

Normally the mesh overall shaping is best defined by specifying that the warp threads define the model. This allows the weft threads to be at large angles to the warp threads without affecting the model shape. Optionally this preference can be turned off, and then both the warp and weft threads are used to determine the overall model shaping. This is mainly used to duplicate models made with earlier version of MPanel.

In some models it is useful to straighten the warp threads. This applies particularly to fixed edge models where there is a sudden change in mesh warp thread spacing, causing the warp threads to bow. The option "Straighten warp threads" can be used in these situations, but on some model shapes may have unexpected consequences.

Optionally the internal modeling tensions can be fixed at 1. This is only used in exceptional circumstances, such as transferring an MPanel Pro mesh model to a links only model. See [Internal model](#) for a description of the modeling tension.

Optionally the mesh "even spacing" can be turned off. Normally MPanel Pro uses an even spacing algorithm to make the mesh more evenly spaced across the model. This can lead to problems in awkward shaped models, and can be turned off then.

Optionally the internal link model can be displayed. MPanel Pro translates the drawing model into an internal model built solely from links with different assigned properties. This model can be drawn out for inspection, but has no further purpose. See [Internal model](#) for more information.

Optionally the model can be mirrored about a mesh edge. This option is set in the [extended data](#), and allows large symmetrical models to be created and relaxed more easily. The mirroring is done with a vertical mirror, ie as though you were looking down on the model. Usually the mirrored edge is fixed at it's corners. Theoretically a model could be mirrored on several edges at one time, but care is required in the resulting interpretation.

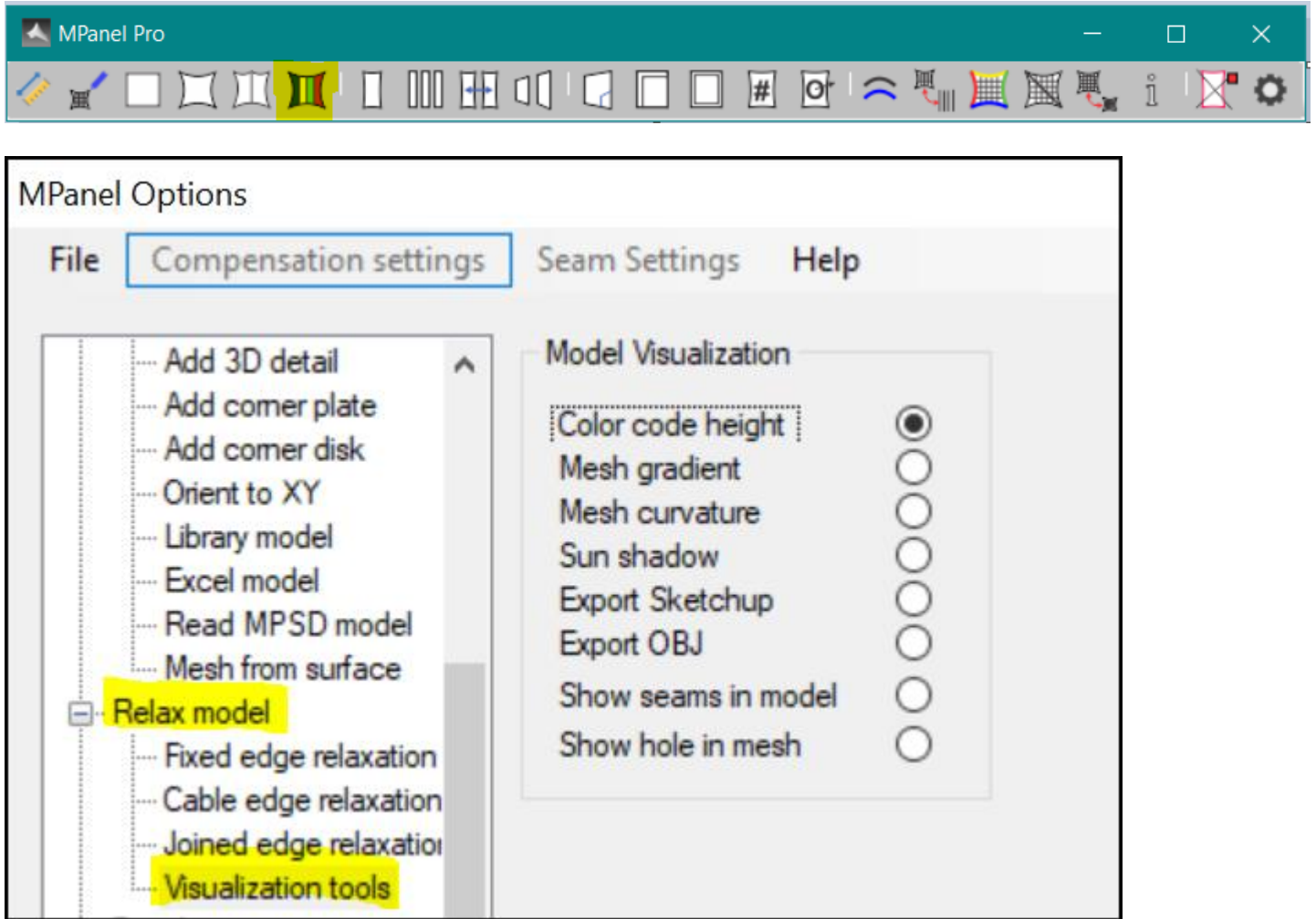

Model Visualisation is a tool that shows information about the model that can be useful for design and communication with clients. The images produced by this tool are not usable as input for other MPanel Pro tools, they are just for interpretation and presentation.

- Color Height
- Mesh Gradient
- Mesh Curvature
- Sun Shadow
- Export Sketchup
- Export OBJ
- Show seams in model
- Show hole in mesh

Color Height

Draws a composite mesh that is color coded for the local mesh elevation, from Blue at the bottom of the model to Magenta at the top. This can help in interpreting the shape of curved surfaces.

Mesh Gradient

Draws a set of lines that indicate the direction that water will travel on the mesh surface. Each line starts at a mesh node, and points in the 3d direction of the local steepest descent. The lines are color coded to indicate the gradient, from flat (Blue) to gradients of 1:1 and above (Magenta).

Areas of possible ponding would be indicated by blue lines pointing in towards each other. but note that the gradient is shown for the mesh shape as designed, with no external loading. Low gradient areas can be expected to deflect downward under water / snow loading, so ponding may occur in the deflected shape even when it is not indicated in this gradient plot.

Mesh Curvature

Will take a set of meshes and draw crosses representing the local mesh curvature at each node.

The crosses each consist of a Green and Blue or Red lines,

The Green line shows the direction of the mesh principle curvature. It's length is proportional to the principle curvature.

The Blue line shows the direction of the mesh second principle curvature. It's length is proportional to the second principle curvature.

If the surface is locally inflated (ie the mesh curvatures have the same sign) then the second principle curvature is drawn in Red

This has use in showing flat spots in a model, in understanding the mesh shaping, and also in understanding the best direction to panel in.

Also any red lines would indicate a mesh shape that could not be supported by tensile forces alone.

The best direction to panel in is in line with the second principle curvature, ie along the Blue lines. This allows the seams to take care of as much of the principle curvature as possible in the panel edge curvature.

So looking at a mesh curvature plot:

When the curvature is significant (large crosses)

When the principle curvature is bigger than the second principle (Green line longer than Blue line)

Then you should panel along the Blue lines.

Sun Shadow

Draws out a flattened copy of the meshes on the Z=0 plane, in the position that the shadow would be. The shadow position is determined by the site latitude and longitude, the date and time of day, and the time zone that the site is in. A time and date stamp is added to the shadow drawing.

The latitude and longitude can be entered in degrees, minutes and seconds, or in decimal degrees (but is converted to and stored in decimal degrees). The suffix S, N, E, W can be used after the entry, so that a typical latitude and longitude would be 54.7 N 20.1 W

The time zone is the number of hours ahead or behind from UTC (Coordinated universal time, more commonly known as GMT for Greenwich mean time). So using this setting you can also allow for local summer time settings.

Usually a CAD drawing will have North straight up along the Y axis when in Top View. If this is not the case then the angle between North and the Y axis can be entered, in degrees clockwise, like a compass.

Export Sketchup

The model can be exported in mpx format, suitable for reading with Sketchup. The image in Sketchup can be rendered, shaded, fogged, etc.

To read the exported file in Sketchup you need the MPanel Pro Import plug in. You can install this from the MPanel Pro Options menu under File... Import Sketchup plug in. Once this is installed the model can be shown in Sketchup using the menu item Plug ins... Import MPanel Pro model.

Make sure that the MPanel Pro selected units are the same as the Sketchup units, or the model may be scaled.

Export OBJ

The model can be exported in obj format, suitable for reading with Awning Composer, and other software that read OBJ files. Once the model is read into Awning Composer you can render, add material textures, apply sun shadows, etc.

Show seams in model

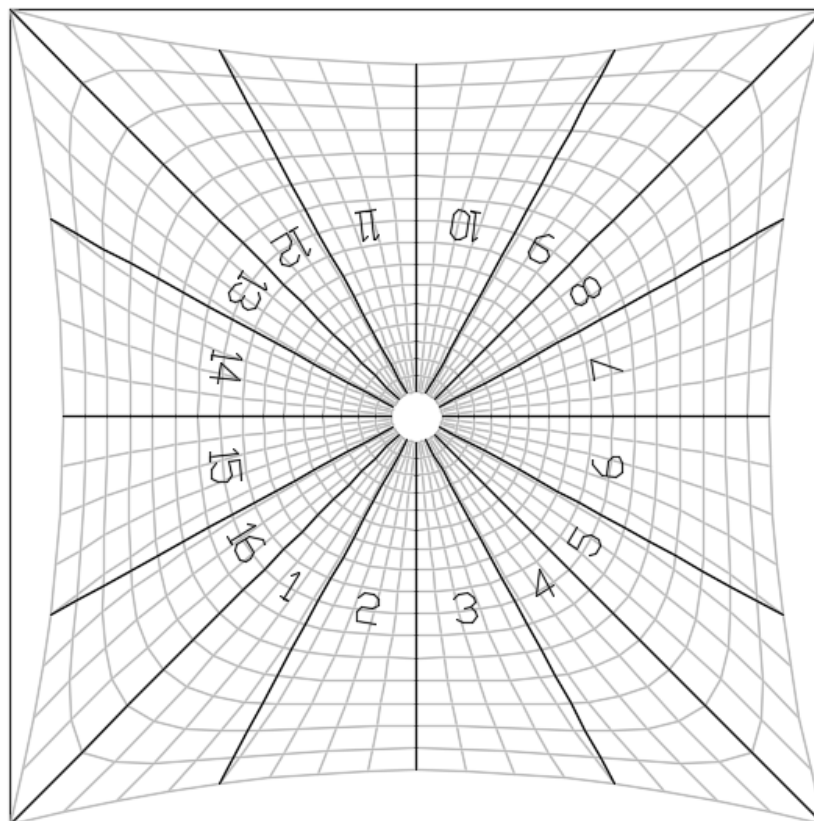
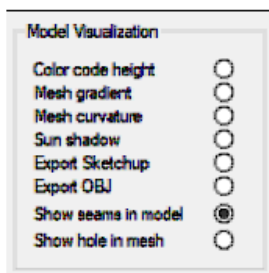

The main seams and panel numbers can be simply superimposed onto the model using this tool. After paneling the model select the model and the panels then run the Show seams in model tool to combine the two.



Video: [Show Seams in model](#)

Show hole in mesh

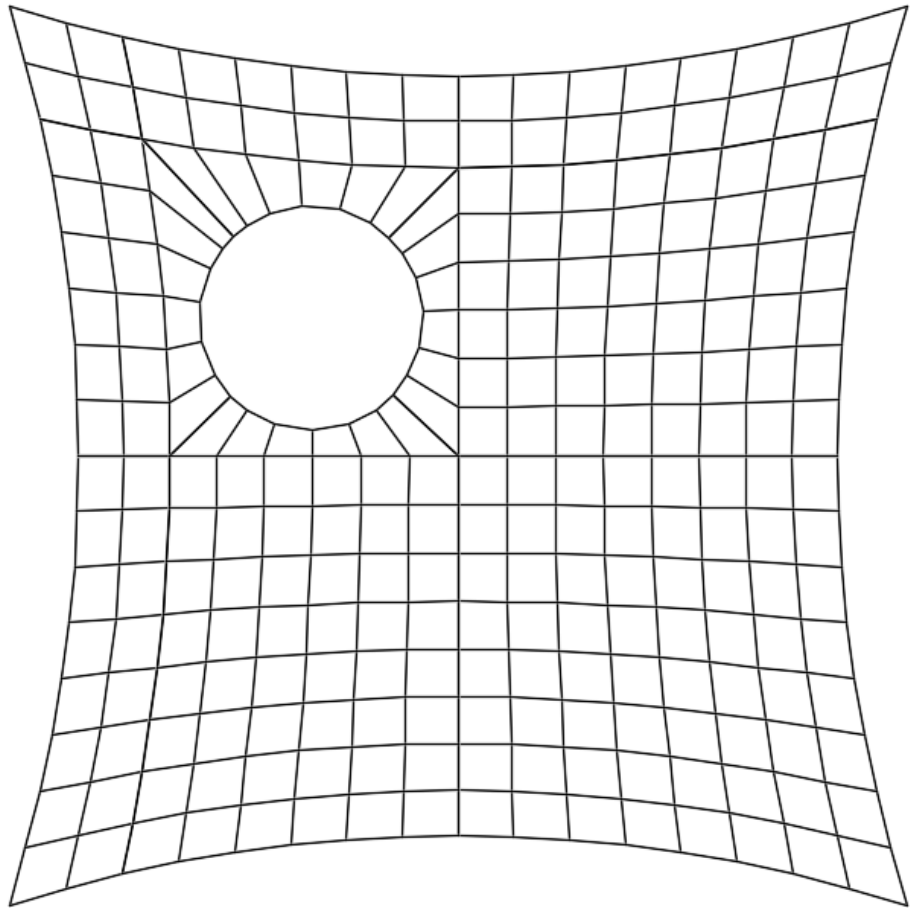
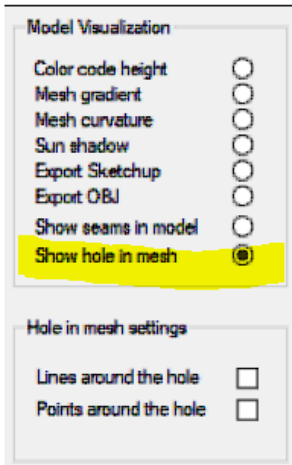

This tool will place a smooth hole in any mesh for visualisation purposes such as 3D models for client presentations. To add a hole simply draw a circle anywhere above the mesh then select the circle and the mesh and run the Show hole in mesh tool. The options to add lines around the hole provide a limited ability to include the hole in relaxation however, this can result in instability in the model so it is not recommended. The recommended approach to locating the hole on the fabric panels is to use the option to add points around the hole. The set of points can be copied to the original mesh (without the hole) prior to paneling in order to include hole location on the panels. The points should be colored to any primary color (green/yellow etc) and then when paneling the mesh select the option to join colored points.



Video: [Show hole in mesh](#)

Panel between Polylines

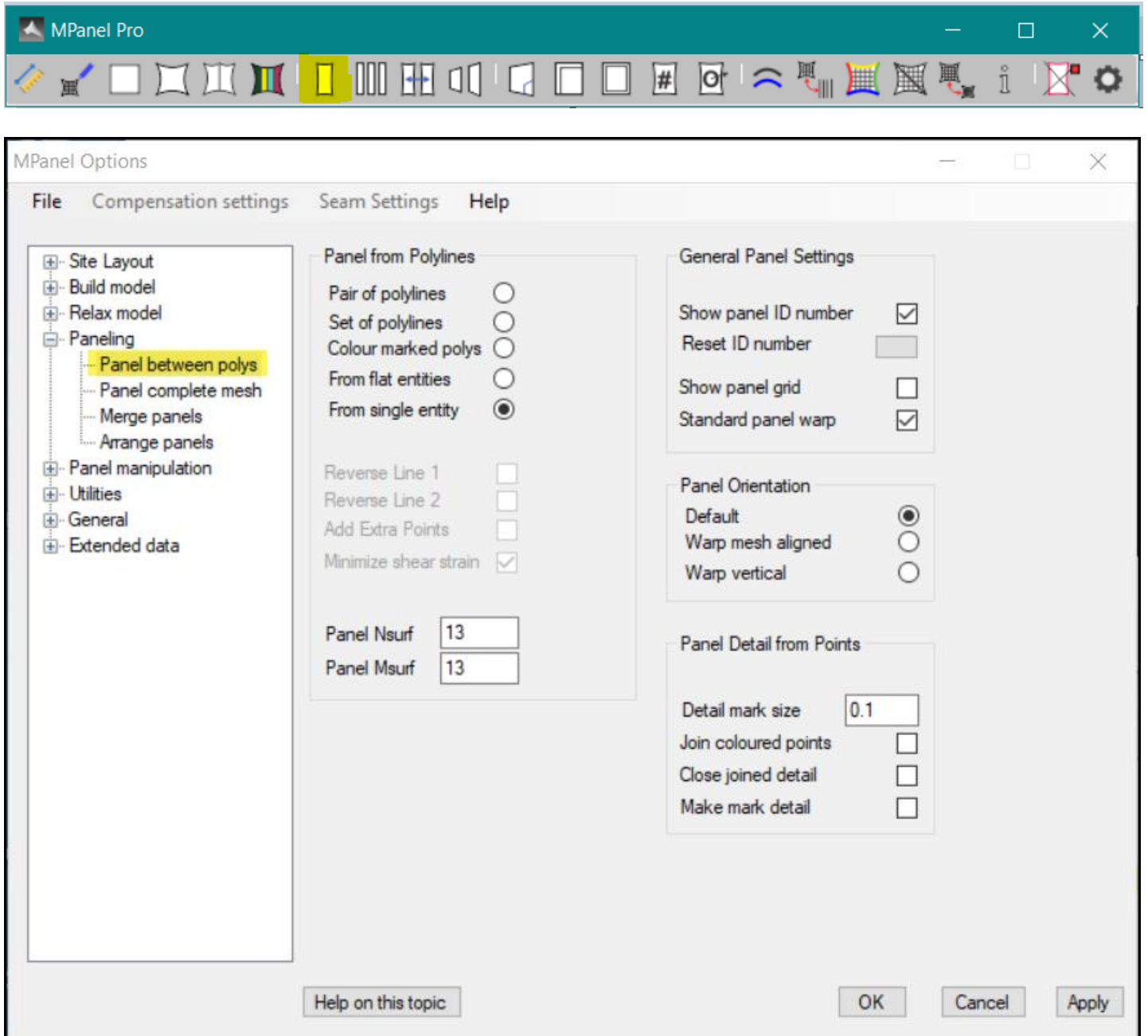

Panel between Polylines will create a flat panel from 3D polylines. It can perform the following functions, as set in the options:

- Panel between a pair of polylines
- Panel a set of polylines
- Panel a color marked set of polylines
- Panel from flat entities.
- Panel from single entity.

All panels can have their internal Panel ID number shown in large numbers on the panel for identification, This is automatically removed during panel output.

Panel between a pair of polylines

This tool takes two 3D polylines and computes the "tightest possible" surface between them. Locally this is a flat panel, but the whole panel will generally be curved.

The tool can accept 3D polylines with different numbers of nodes, and extra nodes will be inserted to make a panel with

the same number of nodes on each side. This feature is selected in the options. The Polylines must be simple polylines, i.e. no arcs or smoothing. It can cope with 3D polylines that are drawn in different directions, i.e. one drawn "up" and one drawn "down", by reversing one or the other.

In general there is always an error when creating a 2D surface to fit between 3D boundaries. To minimise the errors select the option to "Minimise the shear strain". This both halves the error and avoids the error from compounding. The paneling errors are reported as the equivalent shear strain. See the [Modeling and Paneling Errors](#) topic. The shear strain is recorded in the panel as extended data.

The panel is drawn out in XY and should be viewed in TOP (XY) view.

Panel a set of polylines

This tool takes a set of 3D polylines, internally creates the panels between each pair, and merges the panels together to produce one panel that will typically have some end curvature. The shear strain reported for this operation is the sum of the paneling strains and the merging strains.

The lowest shear strains are obtained by using panel sets that merge together in pairs, ie 2, 4, 8 or 16 panels. These need 3,5,9 or 17 polylines in the set.

To obtain the lowest shear strain, the best merging point for each of the internal merges is computed separately. On some extreme merges this may cause unexpected panel shapes. If the "Minimum Strain Merge" is not checked then the same averagely good merging point will be used for all internal merges. The shear strain is recorded in the panel as extended data.

Detail points, in 3D, can be included with the polylines for paneling. They should be drawn as ordinary points, placed close to the local surface of the polys. During paneling an annotation mark will be added the correct 2D place. This feature can be used to position artwork, define cutouts, etc. Optionally, if the points are colored, the annotation marks can be joined together to form a detail poly. Several different joined up sets can be defined by using different point colors. Points of the same color are only joined if they are separated by half the panel length, so detail on two panel corners can be regarded as separate, even if they have the same color.

Optionally, the points can be defined as mark detail, which is used to define the position of a mark line in the seam program.

Panel a color marked set of polylines

This tool takes a set of 3D polylines and uses the "**Panel a set of polylines**" routine to make several panels in one operation. The panels edges are marked in the set of polys by coloring them a distinct color.

For example, a set of black polylines could be paneled into 4 panels by coloring 5 of the polylines blue, to mark the panel edges. The colors used should be simple colors, like the colors in the CAD color pick box.

A set of polys produced by the Cross Section tool, with the "extra polys" drawn in grey, will work with this tool to make a several panels in one operation.

Mark points are supported in the same way as in the "Panel a set of polylines" tool.

If one of the coloured polys is made a different color to the others then this will become the reference poly and panels will be created and numbered starting from the reference poly and proceeding in a counter clockwise direction to finish again at the reference poly.

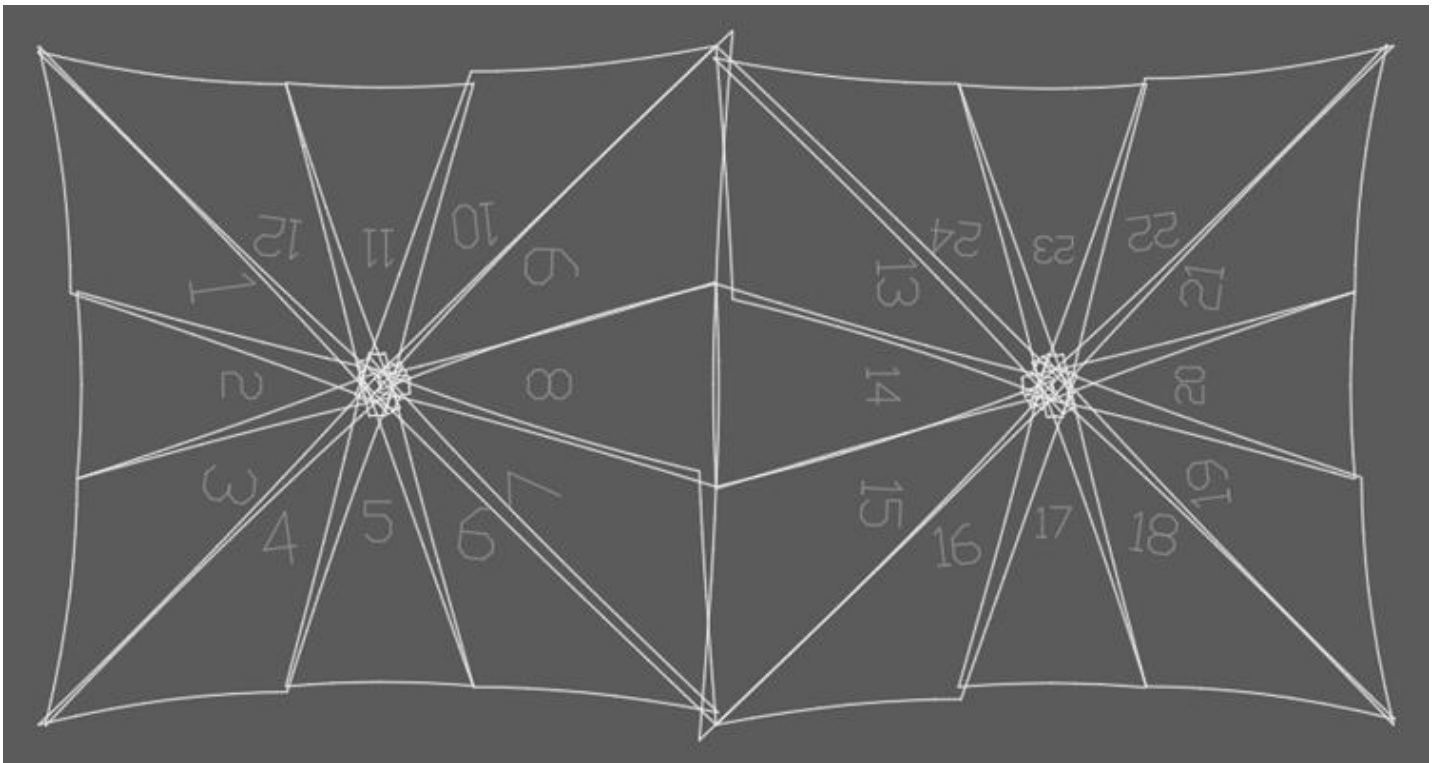
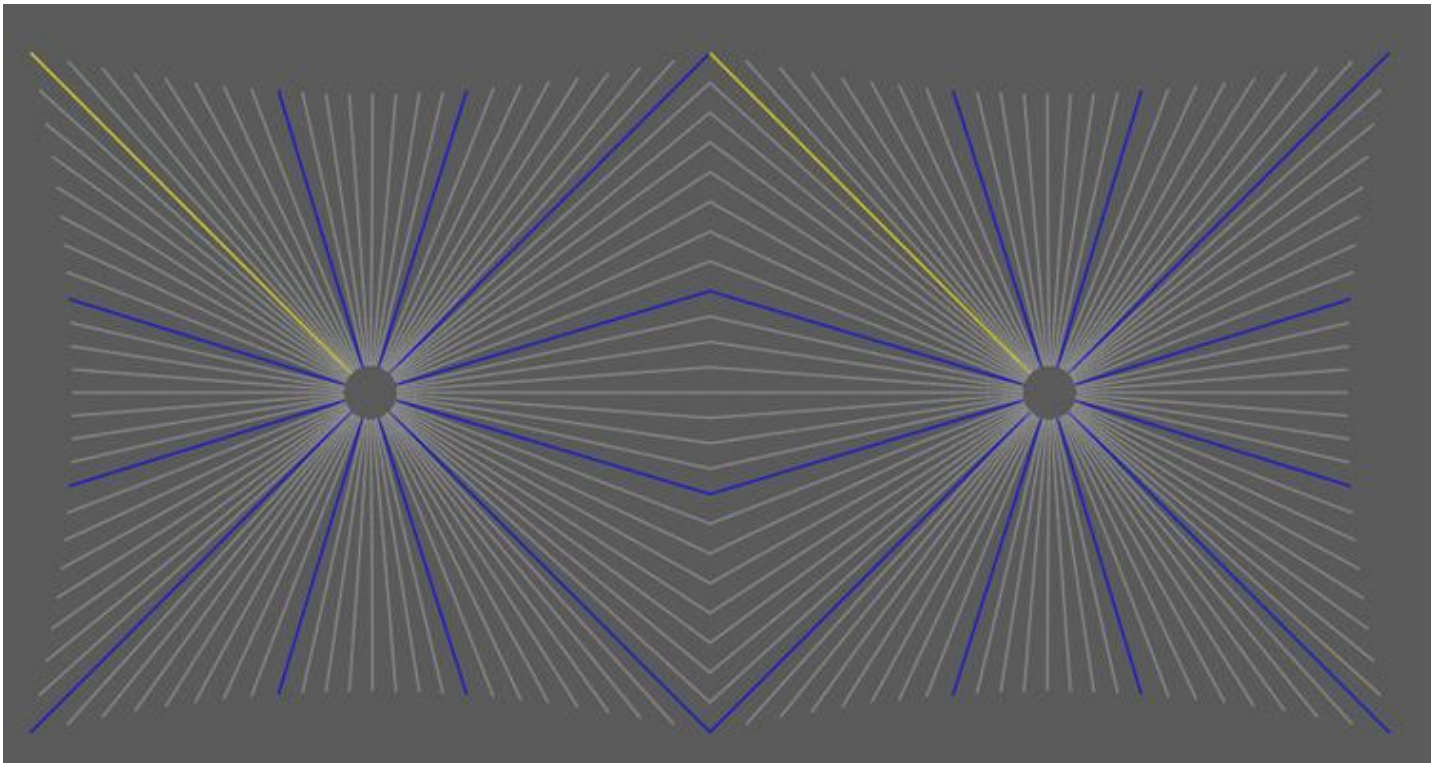

Panel from flat entities

There is a need to create panels directly from flat entities. These could be fill-in panels, non stressed panels, etc. With this tool any 3 or 4 simple entities, including lines, arcs, splines, 2dpolys and 3dpolys, can be used to define a panel. The entities should join at the corners, and should be oriented on the screen so that the top, bottom, left and right are distinct. If it is a triangular panel we assume that there is a bottom, left and right.

The panel will be generated with the number of points on the left and right sides defined by the Nsurf setting, and the number of points on the top and bottom defined by the Msurf setting. Usually the points will be evenly spaced along the panel.

If the original entities are 2dpolys or 3dpolys, and if they have the same number of points as specified in the nsurf and msurf, then the original entities nodes are copied to the new panel, without evenly spacing them. This allows a panel

produced by a third party to be imported into MPanel Pro exactly. This panel could then be compensated, seamed, and output by MPanel.

Panel from single entity

Converts a single closed entity (circle, polygon, spline blob) into an MPanel Pro standard panel. This is particularly useful for producing panels for nesting.

The panel will be generated with the number of points on the left and right sides defined by the Nsurf setting, and the number of points on the top and bottom defined by the Msurf setting. Usually the points will be evenly spaced along the panel.

This panel could then be compensated, seamed, and output by MPanel.



Video: [Panel from single entity](#)

General Notes

By default, the panels lie on top of the polylines that created them. If you choose 'warp vertical', then the panels are aligned with the warp vertical, so the left side of the panel is on the left side of the screen.

Panels can have their internal generation grid drawn out with them, by choosing 'Show Panel Grid'. These grids are derived directly from the 3D mesh, so they act as a placement grid for graphics, cutouts, etc.

Panels can be triangular, that is they can be missing a top or a bottom edge. These panels will still seam, compensate, stamp and output correctly. However the panels must have left and right edges to be processed correctly. If a set of polylines are paneled where the top ends all join together, the panel produced will be triangular.

Panels are issued an internal ID number, which is preserved through all paneling processes, and can be used to trace panels through the drawing. The Panel ID can be inspected with the MPanel Pro Info tool. The panel ID can also be shown on the panel, in large print, by selecting the option "Show panel ID number". You can also manually reset the next panel ID number, but be aware that this might result in panels with duplicate internal panel numbers.

Panel Mesh

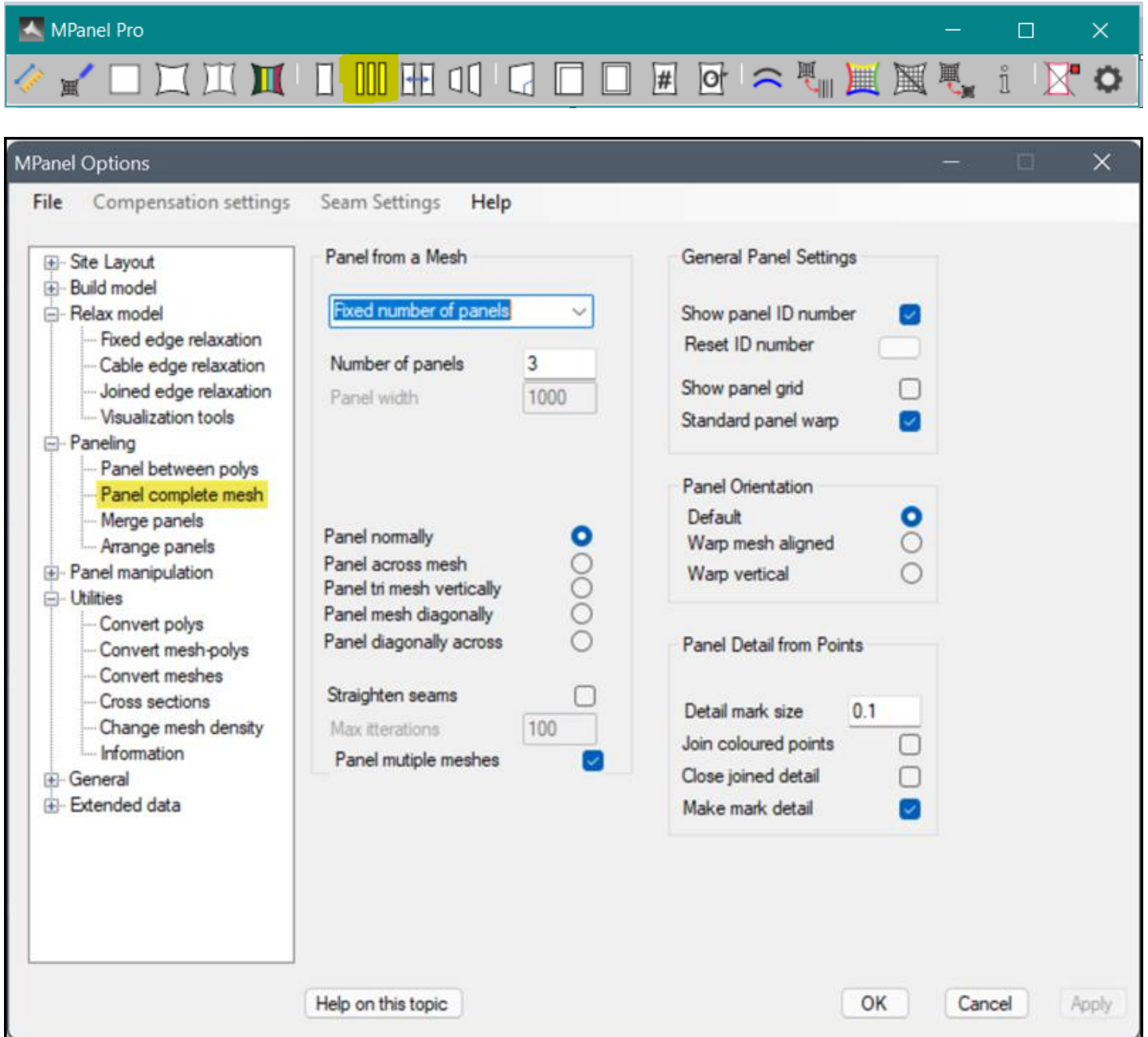

Panel Mesh takes a 3D Mesh, usually after relaxation, and produces a series of flat panels from it. If the Panel multiple meshes option is checked then the settings will apply to more than one mesh (to all meshes selected).

The mesh is considered to consist of N and M threads, with the M threads running from the bottom to the top of the mesh, and the N threads running across. The number of N and M threads are called $nsurf$ and $msurf$ respectively. The mesh is normally paneled in line with the M threads.

The panels are drawn out in XY and should be viewed in Top (XY) view.

The number of panels to be produced from the mesh can be specified by number or by a fixed width. It is best practice to use a number of panels that divides the mesh evenly, so that the mesh threads can be used to create the panel. So a mesh with $MSurf = 13$ (12 spaces between the mesh threads) will divide evenly into 1, 2, 3, 4, 6 or 12 panels.

If the number of panels does not divide the mesh evenly then interpolated threads are used, which provides a good approximation to create the panel from. If the mesh contains more than 4 corners, draw a 3D polyline at each extra corner to ensure that the interpolation between threads will catch the additional corners on the mesh edge. Note, a 3D poly in Rhino is a line with more than 2 vertices (i.e. draw a line with 3 clicks such as a "V" or "L" shape) or alternatively, use the "Draw 3D Poly" tool in MPanel Pro model builder. Select the mesh and the 3D Poly at the same time before running the Panel a mesh tool.

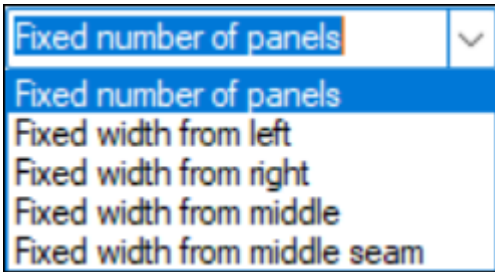

Paneling by a fixed width will produce panels which approximate the specified width to an accuracy of up to 1% less than the specified width. Panels of fixed width can be created starting from the left or right edges of the mesh or from the middle of the mesh with the option of starting from a full width panel in the middle or a seam in the middle.

Paneling from the mesh threads produced panels with curved, evenly spaced seams. The seam shape is visually similar to the closest edge shape, and this gives panels that are visually appealing, with the seams visually reinforcing the perceived shape of the mesh.

However to ease production you can optionally specify "Straighten seams", which will try to make the seams straighter by using geodesic cross sections. This works well in most situations, but will fail if the straighter seam lies outside one of the mesh edges and can result in panels with unacceptably narrow centre's, even when the straightening doesn't fail. Making geodesic seams is an iterative process, the default number of iterations is 100 which should be adequate for 13 by 13 meshes. Higher density meshes, or meshes with a lot of curvature, will need more iterations.

It is also possible to specify that several meshes are paneled in one operation, each to its own panels. This is usually used when paneling simple shapes, into one panel per mesh.

It is important to realize that all paneling of double curved surfaces involves distortion of the fabric, and checking that the distortion is within acceptable limits is part of the paneling process. MPanel Pro reports the distortion as the equivalent shear strain for each panel in the text window. See the [Modeling and Paneling Errors](#) topic. The shear strain is also recorded in the panel as extended data, and can be read later with the Info tool.

Panels can be made as:

- **Panel normally**

Normal panels following the mesh M threads. This usually gives curved seams, which by following the mesh threads will have an even spaced appearance. Users are prompted to "panel across mesh" when paneling a mesh which has no left or right sides e.g.

a mesh added between two edges, like a bikini top

- **Panel across mesh**

The panels can be created across the mesh, so the panel seams follow the N threads. Otherwise the same as Panel normally.



Video: [Panel mesh made with 2 edges](#)

- **Panel tri mesh vertically**

The panel are produced with seams that lie parallel to mid line in the mesh, running from the middle of the mesh bottom edge to the top corner.

- **Panel diagonally**

Curved cross sections are drawn across the mesh diagonally, in a curve that will bisect the corner angles, to produce diagonal seams.

- **Panel diagonally across**

Curved cross sections are drawn across the meshes other" diagonal. Otherwise the same as Panel diagonally.

It should be noted that the tools Panel tri mesh vertically, Panel and Panel diagonally across will produce panels that appear to have 5 or 6 sides when an odd number of panels is specified. In fact panels have a maximum of 4 edges, but in these cases the top or bottom edges will contain a bend at the mesh corner, which gives the appearance of 5 or 6 sides.

By default, the panels lie on top of the parts of the mesh that created them. If you select 'warp aligned to mesh' then the panels are aligned with the mean mesh direction. If you select 'warp vertical', then the panels are aligned with the warp vertical, so the left side of the panel is on the left side of the screen.

An assumption is made that the outside of the mesh is face up. Care is needed if part of the mesh is outside face down, as those panels will be drawn in mirror image. In this situation the mesh should be rotated in xyz to obtain panels that are the correct way up, as using mirrored panels may cause problems with other MPanel Pro tools.

Panels can have their internal generation grid drawn out with them, by choosing 'Show panel grid'. These grids are derived directly from the 3D mesh, so they act as a placement grid for graphics, cutouts, etc.

Mark points, in 3D, can be included with the mesh for paneling. They should be drawn as ordinary points, placed close to the local surface of the mesh. During paneling they will be assigned to the correct panel, and an annotation mark added the correct 2D place. This feature can be used to position artwork, define cutouts, etc. Optionally, if the points are colored, the annotation marks can be joined together to form a detail poly. Several different joined up sets can be defined by using different point colors. Points of the same color are only joined if they are separated by half the panel length, so detail on two panel corners can be regarded as separate, even if they have the same color. Optionally, the points can be defined as mark detail, which is used to define the position of a mark line in the seam program.

Panels are issued an internal ID number, which is preserved through all paneling processes, and can be used to trace panels through the drawing. The Panel ID can be inspected with the MPanel Pro Info tool or using extended data. Optionally the panel ID number can be shown on screen, it is automatically removed from the panel during the panel output stage. Panel Numbers shown in the MPanel Pro text window are the same as the Panel ID numbers.



Video: [3D Poly add details such as zipper to mesh](#)

Merge Panels

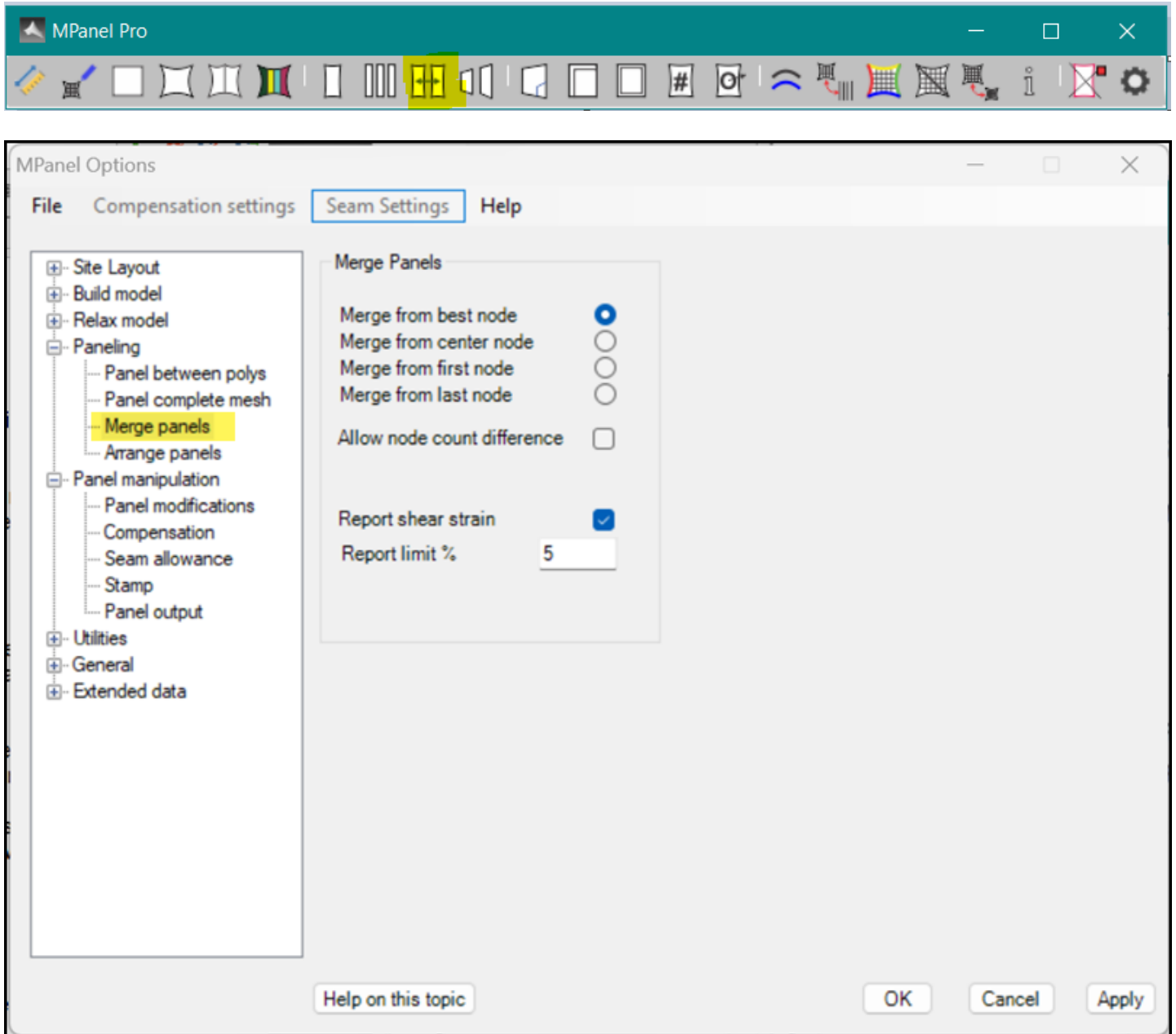

Merge Panels joins together two panels along their inner edges. The inner edges are identified to the program by making them sensibly close together, without the panels overlapping. Both panels are then selected and the tool is run.

The distortion created by merging two different shaped panels together are all moved into the diagonals, causing shear strain. If your fabric can accept shear strain, (i.e. if it is like a net rather than like a film) then merging enables a flat panel to assume a 3D shape. The amount of shear strain you can accept depends on your fabric; on some fabrics it will not be possible to use any significant shear at all, but on an uncoated- coated nylon (F111) 20% shear has been used successfully. See the [Modeling and Paneling Errors](#) topic.

You can merge panels that have been created by merging panels, i.e. with panels A, B, C, D you merge A and B to make AB and merge C and D to make CD. You can then merge AB and CD to make ABCD. The shear strains for each of the panels to be merged are read in from extended data, and added to the shear strain from the merge, to produce a total shear strain for the panel. This is reported in the MPanel Pro text window, and recorded in the panel as extended data.

The edge nodes that the panel merging starts from affects the merged panel shape, and the shear strain. Usually you want to let the program choose the node that gives the lowest shear strain. In some situations you want to specify that the merging starts at the top, the bottom, or the middle of the panel.

In some situations you want to force the merging to start at the edge first node, last node, or in the centre, there are options for these choices.. (The only common use for this is to minimise the distortion on part of the panel, for instance when a reinforcement patch is being made over two panels).

In V27, we introduced a new facility which allows merging of panels with a different number of vertices on the joining edges which was previously not possible. This is particularly useful for joining parts of reinforcement patches which can be created with different edge vertices.

With a low shear stiffness material (i.e. like a net) this technique lets you create very sculpted 3D shapes from a single flat panel.

Any detail polylines in the panel, such as internal grids or added detail, will be moved and distorted with the panels.

Merged panels are new panels that are issued an internal ID number, which is preserved through all paneling processes, and can be used to trace panels through the drawing. The Panel ID can be inspected with the MPanel Pro Info tool.

Panel Arrange

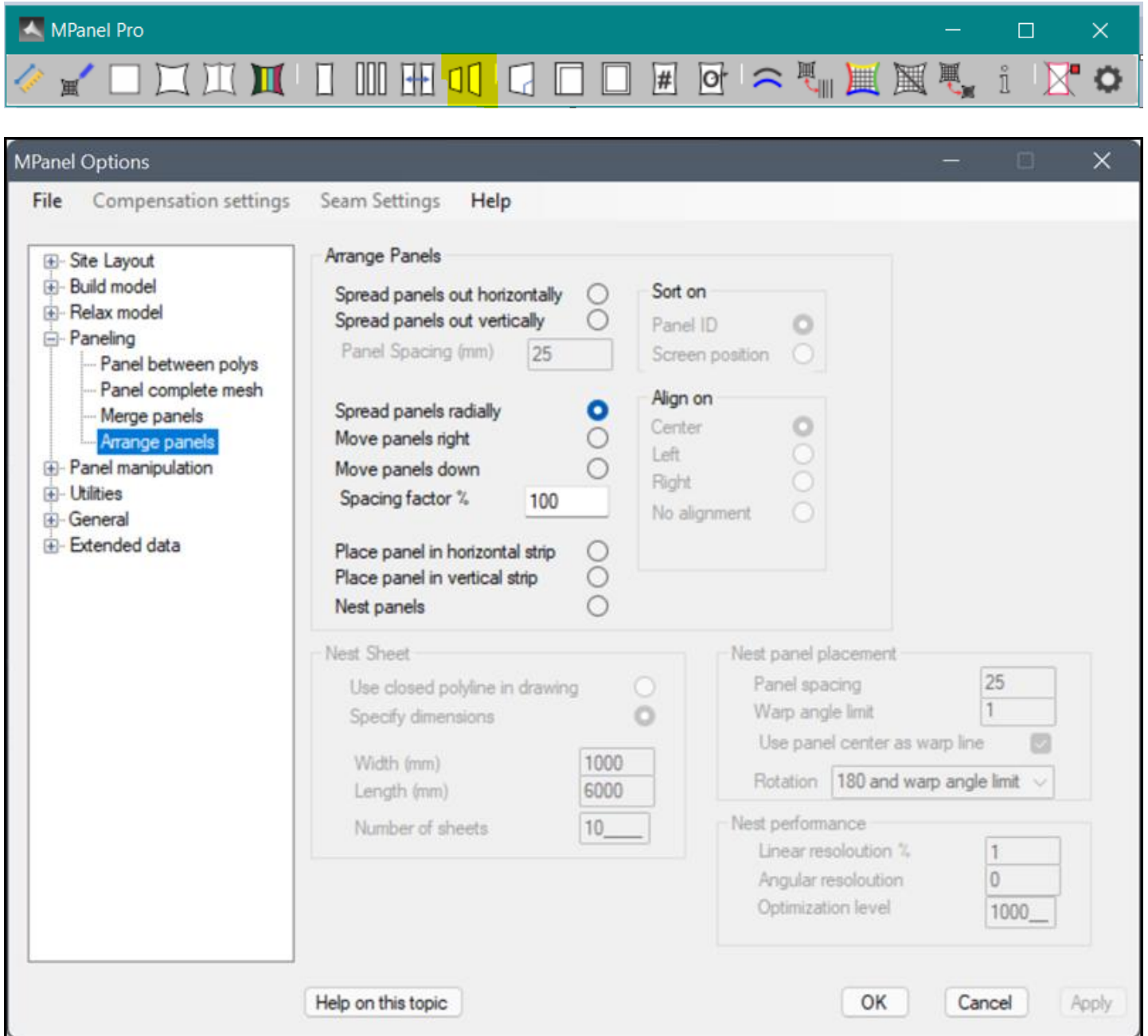

Panel Arrange will arrange a set of panels using the following methods.

- Spread Panels out Horizontally
- Spread Panels out Vertically
- Spread Panels apart Radially
- Move panels right
- Move panels left
- Spread Panels apart Radially
- Place Panel in Horizontal strip
- Place Panel in Vertical strip
- Nest Panels

Spread Panels out Horizontally

This will take a set of panels and draw out a copy of the panel in a row, each panel aligned vertically, with a specified spacing between each panel. The order they are drawn is determined by the panel internal ID number, or the original panels bottom left X coordinate

The vertical alignment can be based on the panel centre line, the panel left edge, of the panel right edge, or no alignment. With no alignment the panel alignment says the same as it is on screen.

This has use when a set of panels, which may be partially overlapping, are produced from a mesh, and need to be spread out to allow further MPanel Pro operations to be carried out on them.

Spread Panels out Vertically

This will take a set of panels and draw out a copy of the panel in a column, each panel aligned vertically, with a specified spacing between each panel. The order they are drawn is determined by the panel internal ID number, or the original panels bottom left Y coordinate

The horizontal alignment can be based on the panel centre line, the panel left edge, of the panel right edge, or no alignment. With no alignment the panel alignment says the same as it is on screen.

Spread Panels apart Radially

This will take a set of panels and spread them apart radially, from the average center of all the panels. The amount of spreading can be specified as a percentage. This has use in spreading panels apart whilst maintaining their original positions relative to each other, like in a set of panels for a conic.

Using this tool is can be a good start when creating alignment marks during stamping.

Move Panels right

This will take a set of panels and make a copy of them to the right, moving them by a an amount based on the specified spacing factor. This has use when showing all the paneling steps in the drawing, and is also used during scripting

Move Panels down

This will take a set of panels and make a copy of them downward, moving them by a an amount based on the specified spacing factor. This has use when showing all the paneling steps in the drawing, and is also used during scripting

Place Panel in Horizontal strip

This will take a single panel, and make a copy of it inside a pair of horizontal guide lines, that represent the fabric roll or the cutting table, in a position that avoids any panels that are presently inside the guide lines, and tries to minimise wasted material.

In use you select the guide lines, the panels already inside the guide lines, and the new panel you want to place. Then run the tool, and a copy of the new panel will be drawn inside the guidelines. You can also specify a minimum spacing between panels.

The algorithm used to find the best position for the new panel is not very strong, and you will sometimes be able to see a better position for the panel by eye. In that case move the panel using normal CAD methods, and then continue placing panels in the strip using this tool.

The panels are not rotated by small angles during this operation. This ensures that the intended warp direction in the panel is aligned with the warp direction of the roll. So you may need to rotate your set of panels to align with the roll before using this tool. This tool will rotate the panel by 180 degrees if that helps to get a better position. If you want to rotate the panels by small angles to obtain a better position, you can do this using normal CAD methods, and then continue placing panels in the strip using this tool.

Place Panel in Vertical strip

This tool works the same as above, except that the guide lines should be drawn vertically

Nest Panels

This tool performs nesting on a set of panels to achieve fabric usage savings. Nesting is an optional module, a license for it's use needs to be purchased separately. The nesting module is described on [this page](#).

Note 1: The MPanel Pro Output tool strips all extended data from the panels, and modifies the panels ready for automatic cutting and plotting. For this reason panels that have been through the Output tool cannot be arranged. So the process is to arrange the panels on the roll, or nest them, and then run the Output tool on the panels.

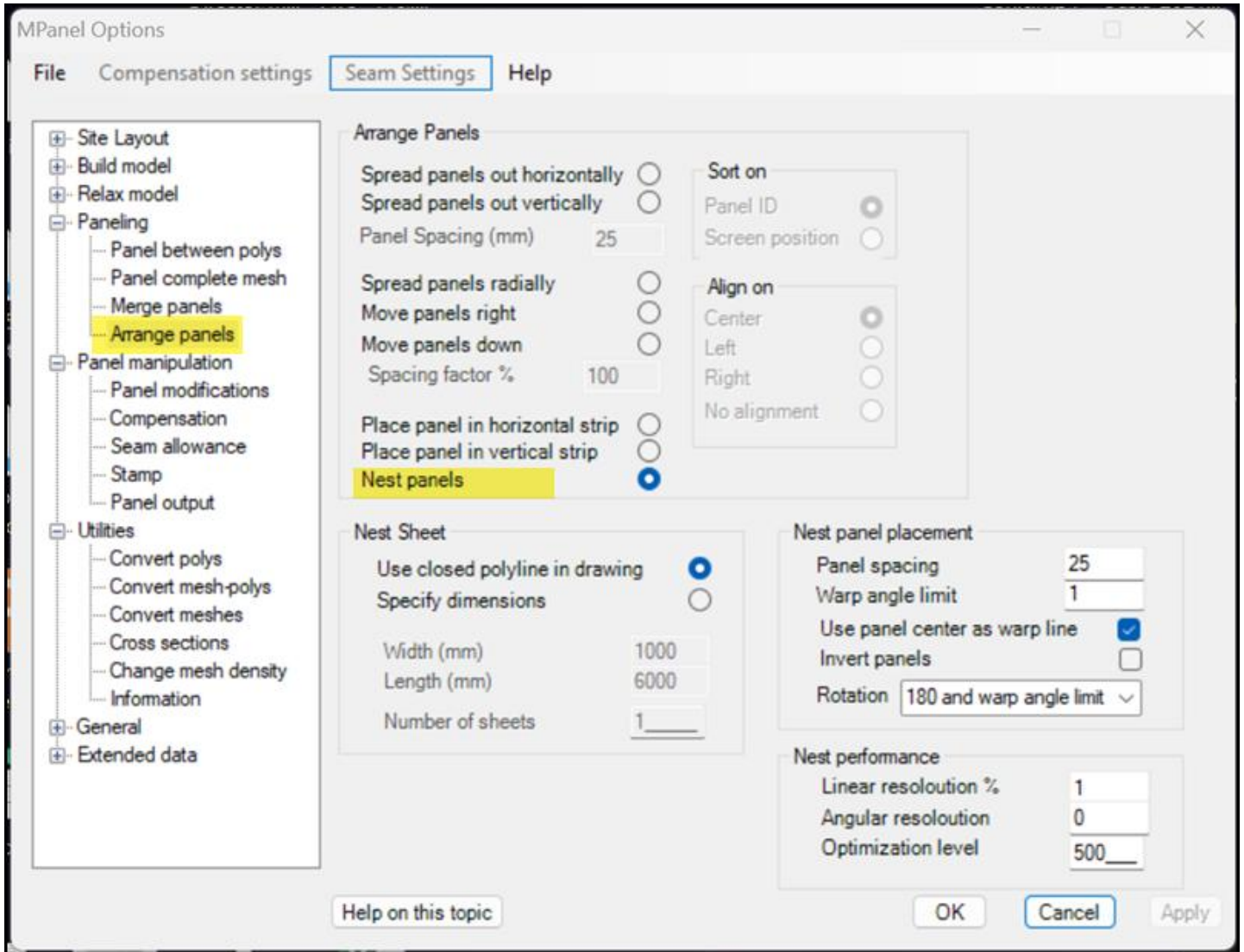

Video: [Nesting](#)

MPanel Pro offers a tightly integrated interface to a powerful nesting library, supplied by Nesting Technologies SRL.

The nesting library is an optional add in to MPanel, and a separate license for its use must be purchased from MPanel Pro Software Solutions.

Nesting is performed on the 'Arrange Panels' button.

Nest panel placement

The panels spacing from each other and the sheet edge can be specified.

The angle that the panel is allowed to rotate during nesting can be:

- plus or minus angles up to the warp angle limit
- 0 or 180 degrees, plus or minus angles up to the warp angle limit
- unrestricted rotation.

The "zero angle" for panel rotation is either:

- a) the panel warp line, if one exists in the panel stamp, or
- b) the panel center line, if the option to use the center line is checked, or
- c) the panel orientation on screen, with the zero angle being horizontal.

In general structural fabrics used in conics, barrel vaults, shade sails, etc will have a small warp angle limit to ensure the warp threads are oriented in the correct direction.

Panels can be inverted during the nest by selecting the Invert Panels option allowing for panels to be marked on the bottom side for production. If selected at Nest stage, users will be warned if they also choose "Invert Panels" in the Output stage of the project.

Allowing 180 degree rotation will give a tighter nest, but may result in unacceptable visual affects with some fabrics.

Non structural fabrics, such as boat covers, interior fabric, etc will often use unrestricted rotation.

Nest performance

Nesting is an iterative process, and in general there is no "perfect" nest. To specify how well the panels are nested you can adjust:

Linear resolution % determines the size of the "hidden grid" on which panels are placed to see how well they nest, as a percentage of the sheet width. Low values gives tighter nests, but will take longer to nest. A reasonable value to use is 1% (default).

Angular resolution is the number of degrees that the panel is tried at between the warp angle limits. So with a warp angle of 20 degrees and an angular resolution of 10 degrees, the panel will be tried at +/- 0, 10 and, 20. A smaller angular resolution will take longer to nest,

Optimisation level controls the numbers of attempts the nesting program uses to achieve the best nest. Increasing this number will increase the quality of the nest, but will take longer to nest. A value of 100 produces reasonable nests. Larger numbers will make better nests, but will take longer.

Specified Sheet Nesting.

In simple nesting, the cutter table size is specified in the Nesting options. The panels to be nested are selected, and the program run. The panels will be nested into sheet sizes, and drawn out below the panel set.

The number of sheets can be specified, and as many panels as can be nested onto those sheets will be used. Or you can specify a large number of sheets (100) and then all the panels will be nested.

The spacing between the panels can specified.

The warp angle limit is the number of degrees that the panel is allowed to rotate from the basic panel angle during nesting. Large values, like 20 degrees, will give a tighter nest, but will allow the finished panel warp to be different from the design panel warp, which may cause difficulties with seam puckering, uneven stretching, etc.

The basic angle of the panel, ie the result if you specify a warp angle limit of 0 degrees, is either:

- As the panel is drawn on the screen, for panel without a warp line (ie, the panels should be horizontal before nesting)
- With the warp line horizontal, for panels that have a warp line added during the stamping operation.

Nesting into a closed polyline

In this case you draw the sheet boundary in CAD as a closed polylines. The sheet drawing and the panels are then selected, and the nest will arrange the selected panels inside the sheet boundary.

This can be used to:

- Nesting onto a partially used sheet or offcuts.
- Nesting around fabric faults.
- Nesting non critical small parts with a high warp angle limit around critical parts with a low warp angle limit.

Nesting Report.

After each nest, a report is sent to the MPanel Pro text window in the following format:

```
Nested 7 of 12 panels
Used 2 of 10 sheets
Sheet 1 Panels: 4 Used Length: 95.5%
Sheet 2 Panels: 3 Used Length: 65.1%
Utilisation = 47.8%
```

Utilisation is the used area percentage within the used length on each sheet.

Progress Reporting

The nesting progress is shown by an increasing number in the MPanel Pro toolbar. The exact number that is needed to complete the nest depends on several factors, but is similar to the specified optimisation level.

A cancel button is shown in the MPanel Pro text window to interrupt long running nests. Also the ESC key can be used when MPanel Pro has the focus.

Nesting License.

The nesting requires an additional on the MPanel Pro license server. Once this has been added the first nest that is attempted will be interrupted to set the nest license on that computer.

To license the nesting, contact MPanel Pro Software Solutions.

Modify Panel

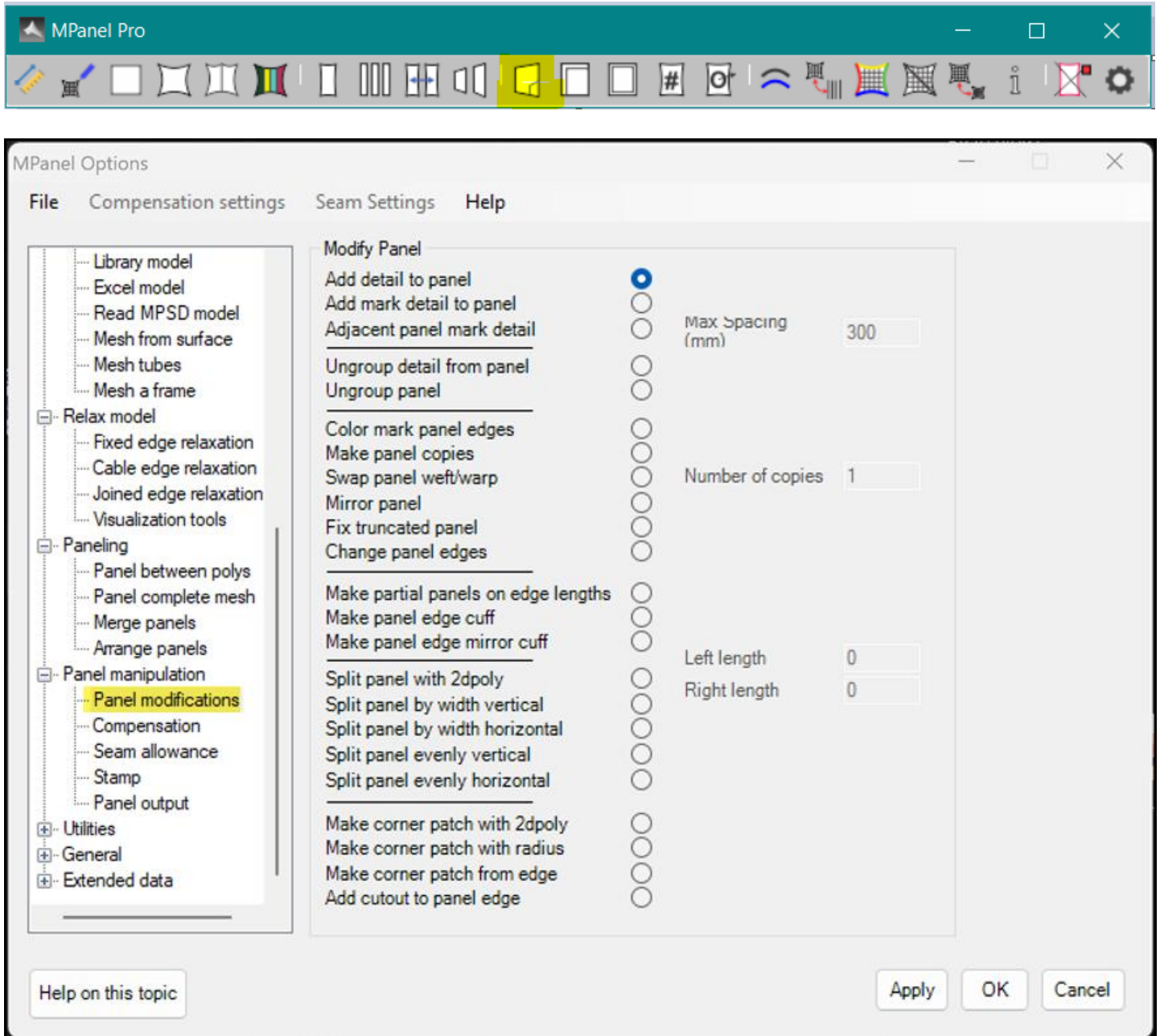

The panel modification tools work on a single panel at a time, and perform the following functions:

- Add Detail to Panel
- Add Mark Detail to Panel
- Mark Detail from Adjacent Panels

- Ungroup Detail From Panel
- Ungroup whole panel

- Color Mark Panel Edges
- Make Panel Copy
- Swap Panel warp/weft
- Mirror Panel
- Fix truncated panel
- Change panel edges

- Make partial from edge lengths
- Make panel edge cuff
- Make panel edge mirror cuff

- Split Panel with 2D polyline
 - Split panel by width vertical
 - Split panel by width horizontal
 - Split panel evenly vertical
 - Split panel evenly horizontal
-
- Make corner patch from 2Dpolyline
 - Make corner patch from radius
 - Make corner patch from edge
 - Add cutout to panel edge

Add Detail to Panel

Add Detail to a Panel allows detail drawings made from polylines to be grouped with the panel. Select the panel and the required detail, and run the tool. The color of the detail is set in the General Options. The details are correctly preserved through merging, compensation, seaming, stamping and output.

Note that the detail must be in the form of polylines (not 3Dpolys) which should contain more than 2 vertices. The '[Poly conversion tool](#)' can be used to convert any other entities into polylines.

This can be used for example to add corner plate detail to panels by converting drawings of circles, arcs, etc to 2D polys with the poly conversion tool.

Or it can be used to draw in graphics or graphic markers, based on the panel grid.

Add Mark Detail to Panel

Add Mark Detail to a Panel works in a similar manner to the above, except that the seam allowance program will convert the detail into a mark line in the seam.

This allows information about graphic positions, structural reference points, etc to be carried through the paneling process to result in an edge mark in the final panel output.

The mark line will be generated by taking the middle node of the polyline and finding the closest point on the panel edge. So with a 3 point polyline node 2 is used, on a 2 point polyline node 1 (the start) is used. Usually the detail is close to an edge, to ensure an accurate mark.

Mark Detail from Adjacent Panels

Panel mark detail can be created from adjacent panels. This is useful if a main panel has several secondary panels that fit along one edge. Arrange the panels roughly as they would fit together, and color the main panel Green. Select all the panels and run the tool. Detail marks will be added to the main panel to show where the adjacent panels will fit on the edge.

If there is a non zero setting for "max spacing", then additional detail marks will be added along the edges of all the panels, so that the detail marks are less than the max spacing apart.

Ungroup Detail From Panel

Detail can also be removed from a panel group. Apart from editing, the main use of this is to delete the internal panel grid after graphics or graphic markers have been added.

Ungroup whole panel

Also, the whole panel can be ungrouped. This occasionally has use when hand modifying panels. The entities can be regrouped using the Add Detail option.

Color Mark Panel Edges

This draws a set of colored polylines inside the panel, to identify which panel edges are top, bottom, left, right, according to the color code:

Red Left edge
Green Right edge
Yellow Top edge
Blue Bottom edge

The colored polylines cannot be used as a panel, they are just to indicate which edge is which on an existing panel.

Make Panel Copy

This makes a copy of the panel, with a new internal panel number. This is useful if you need several identical panels for the drawing, or for [nesting](#). The number of copies can be specified. The new panels are drawn offset to the right of the original panel.

Swap Panel warp/weft

This makes a copy of the panel, with a new internal panel number, and with top_bottom swapped with left-right. This is useful if the original panel was created the wrong way around, or to help with merging panels "Top to bottom". The number of nodes on the panel edges are adjusted to meet panel rules. The new panel is drawn offset to the right of the original panel.

Mirror Panel

This makes a mirror copy of the panel, with a new internal panel number. This is useful when building a symmetrical model when only one half of the structure has been meshed. The new panel is drawn offset to the right of the original panel.

Fix truncated panel

When paneling with cross sections on the diagonal the corner panels are truncated due to the last cross section. This tool "fixes" the panel to include the missing part by extending the panel edges into a triangle. Note that this will change the orientation of the panel as the triangular panel must have left and right sides, so the inside edge of the panel becomes either a top or bottom edge.

Change panel edges

Panels can be created through merging panels, joining meshes, paneling merged meshes etc. which may have edges which do not meet your design requirements. This tool allows you to change the edge orientation to suit your needs. Simply draw a line between 2 vertices to represent the left edge (color it red) and repeat this for the right edge (color green) then select the panel and the lines and run the tool (delete old) to change the panel edges.

Make partial panels from edge lengths

A panel can be split by defining the edge length distances of the left and right edge from either the top or bottom of the panel. This will result in 2 new panels which maintain the orientation of the original panel. This can be used for making top ring reinforcement patches, including star shaped reinforcements.

Make panel edge cuff

A small panel is created that is a specified trim length from an edge. This forms the basis of an edge cuff, which can be

used to provide a cable tunnel on the mesh edge.

Make panel edge mirror cuff

A small panel is created that is a specified trim length from an edge. This forms the basis of an edge cuff, which can be used to provide a cable tunnel on the mesh edge. This panel is mirrored around the selected edge and the new panel has the same edge definition thus ensuring the same warp/weft direction.

Split Panel with 2d polyline

The panel can be split into two, along a polyline that crosses the left and right (or top and bottom) panel edges. The new panels maintain the orientation of the original panels. The number of nodes on the each panel edge are adjusted to meet panel rules. This tool can be used for splitting panels into colored segments, for artwork purposes, for making reinforcement patches, or bottom edge cable cuffs. Rhino users will need to use the MPanel Pro Poly convert tool to convert a Rhino curve to a 2D poly.

Split Panel by width vertical

The panel can be split into specified widths, from the left edge, right edge, or from a center panel. This is useful when a large panel needs to be made from smaller strips, but care needs to be used to make sure that the end panels are satisfactory, that is that they are not too thin to handle, and that they have not crossed curved panel ends.

Split Panel by width horizontal

The panel can be split into specified widths, from the left edge, right edge, or from a center panel. Note that the panel orientation is assumed to be left edge on top and right on the bottom and the split fabric width warp direction will run from left to right (of the screen). This is useful when a large panel needs to be made from smaller strips, but care needs to be used to make sure that the end panels are satisfactory, that is that they are not too thin to handle, and that they have not crossed curved panel ends.

Split Panel evenly vertical

The panel can be split evenly into specified number of panels. This is useful when a large panel needs to be made from smaller strips, but care needs to be used to make sure that the end panels are satisfactory, that is that they are not too thin to handle, and that they have not crossed curved panel ends.

Split Panel evenly horizontal

The panel can be split evenly into specified number of panels. This is useful when a large panel needs to be made from smaller strips, but care needs to be used to make sure that the end panels are satisfactory, that is that they are not too thin to handle, and that they have not crossed curved panel ends.

It should be noted that spitting by width generally produced a less visually pleasing seam placement than splitting the panel evenly. Best results will be achieved by orienting panels perfectly verical or horizontal before splitting.



Video: [Panel Splitting Tools](#)

Make corner patch from 2d polyline

A new panel can be defined by a polyline that crosses a corner of the original panel. The new panel always has a left, right, and top edge. This tool can be used to make reinforcement patches in panel corners. The number of nodes on the each panel edge are adjusted to meet panel rules

Make corner patch from radius

This creates a curved triangular panel at each selected corner with the size determined by the radius setting. These can be used as reinforcement patches. The panels will always have a left, right and top edges, so can have seam allowances added if needed.

V30 adds an estimated reaction angle line to the reinforcement patch - see video linked below:



Video: [Corner reinforcement patches with estimated reaction force angle](#)

Make corner patch from edge

A new panel can be made from a panel edge, where the edge contains a significant angle change. This can be used to create a prototype reinforcement patch, that will be refined with other tools, for panels with an edge that spans a corner. The edge that the panel is derived from is specified in the options.

Add cutout to panel edge

The panel cutout tool is useful to add cutouts to panel edges to avoid obstacles or allow for structures such as downpipes etc. There are several ways to employ this tool the simplest example is adding a poly line normally to the panel with seams already added, then select the poly and the panel and the shape will be cutout.

For a smoother detail we can use an arc or some other shape, then use the MPanel Pro tool to convert the arc to a poly and then run the tool.

If the details are measured digitally at the time of surveying the site, they can be added to the mesh as a series of points and then change their color.

Now in the panel a mesh tool we select join colored points and run the panel tool which applies the detail to the panel and when we run the panel cutout tool, MPanel Pro will use the detail as a cutout.



Video: [Panel Cutout](#)

Compensate Panels

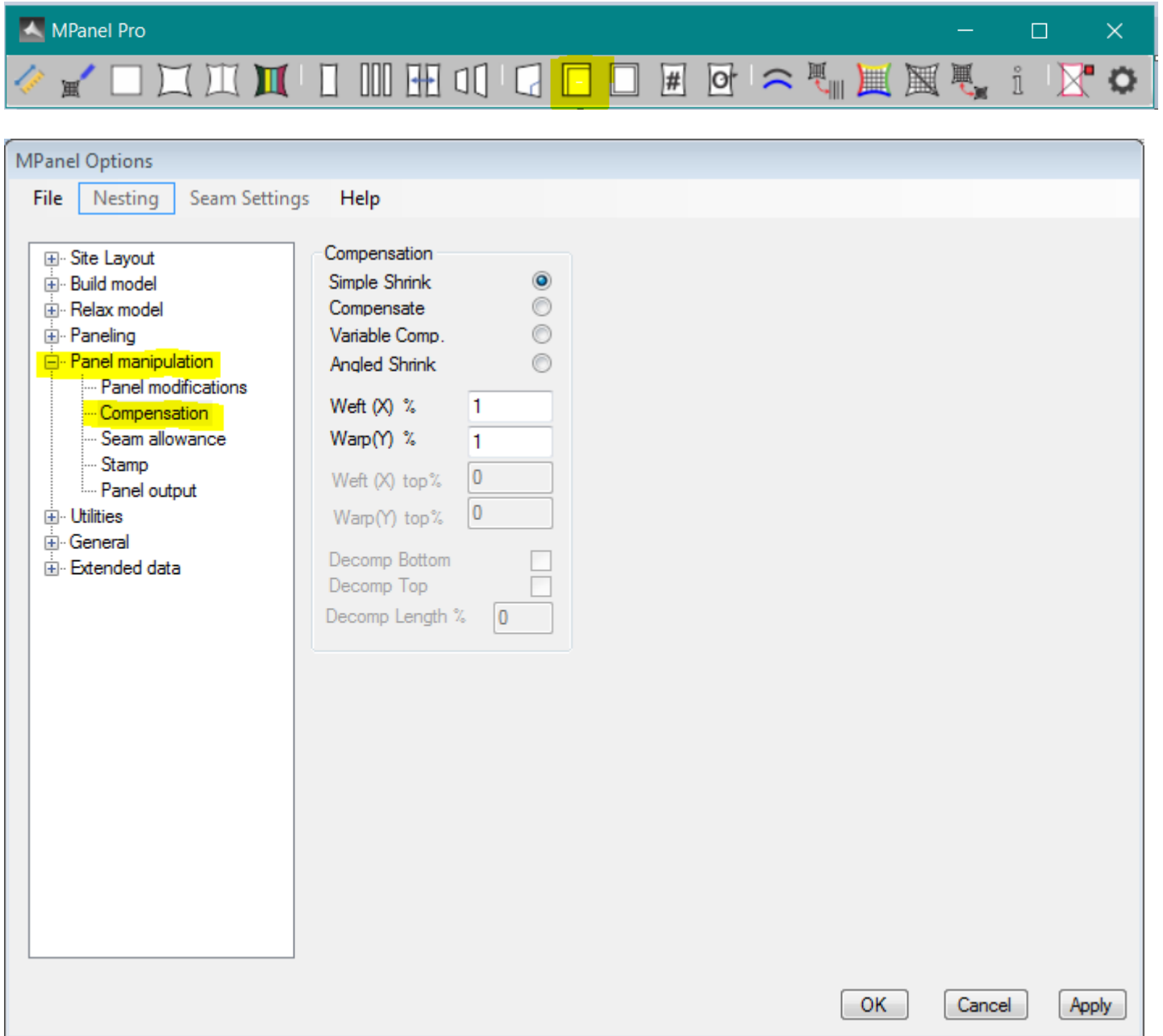

Compensate panels will shrink a panel or a set of panels by a controlled amount, to introduce pre-stress in the finished model. It can perform the following functions, as set in the options:

- Simple Shrink
- Compensate
- Variable Compensation
- Angled Shrink

Simple Shrink

This tool takes a panel and applies differential shrink to allow for pre-stress.

The panel Warp(Y) axis is the center line of the panel, running between the warp sides, and the panel Weft(X) axis is at right angles to this line. A 2% weft compensation will shrink the panel to 98% across the panel.

Compensate

This tool applies the Warp and Weft compensation locally, ie the Weft is locally across the panel and the Warp is locally along the panel. Optionally the weft compensation can be feathered out at the ends, over a percentage of the panel length.

The panel Warp(Y) is the curved line running halfway between the warp sides, and the panel Weft(X) axis is at local right angles to this line.

Variable Compensation

This tool applies the Warp and Weft compensation locally, ie the Weft is locally across the panel and the Warp is locally along the panel. The compensation value can vary linearly from the bottom of the panel to the top. Otherwise the operation is the same as Compensate.

Angled Shrink

This tool applies the simple shrink method to the panel, but with the panel warp(Y) and the panel weft(X) axis being the Y and X axis on the screen. This allows the panel to be shrunk at an angle from the panel warp direction.

Standard Panel Warp Direction

Usually the "Standard Panel Warp Direction" checkbox should be ticked, as this forces the program to use a panel warp that lies between the two warp edges, which are marked on the panel in the extended data. In some situations you may want to override this, and use a panel orientation where the panel warp is midway between the most vertical panel edges as viewed on the screen in top view. You do this by setting 'Standard Panel Warp Direction = Off' under the 'Panel Tools' tab on the Options Screen.

The compensation settings can be saved in a database through the menu item "Compensation settings". Using this feature a library of compensation values suitable for different fabrics and applications can be built up.

Seam Allowance

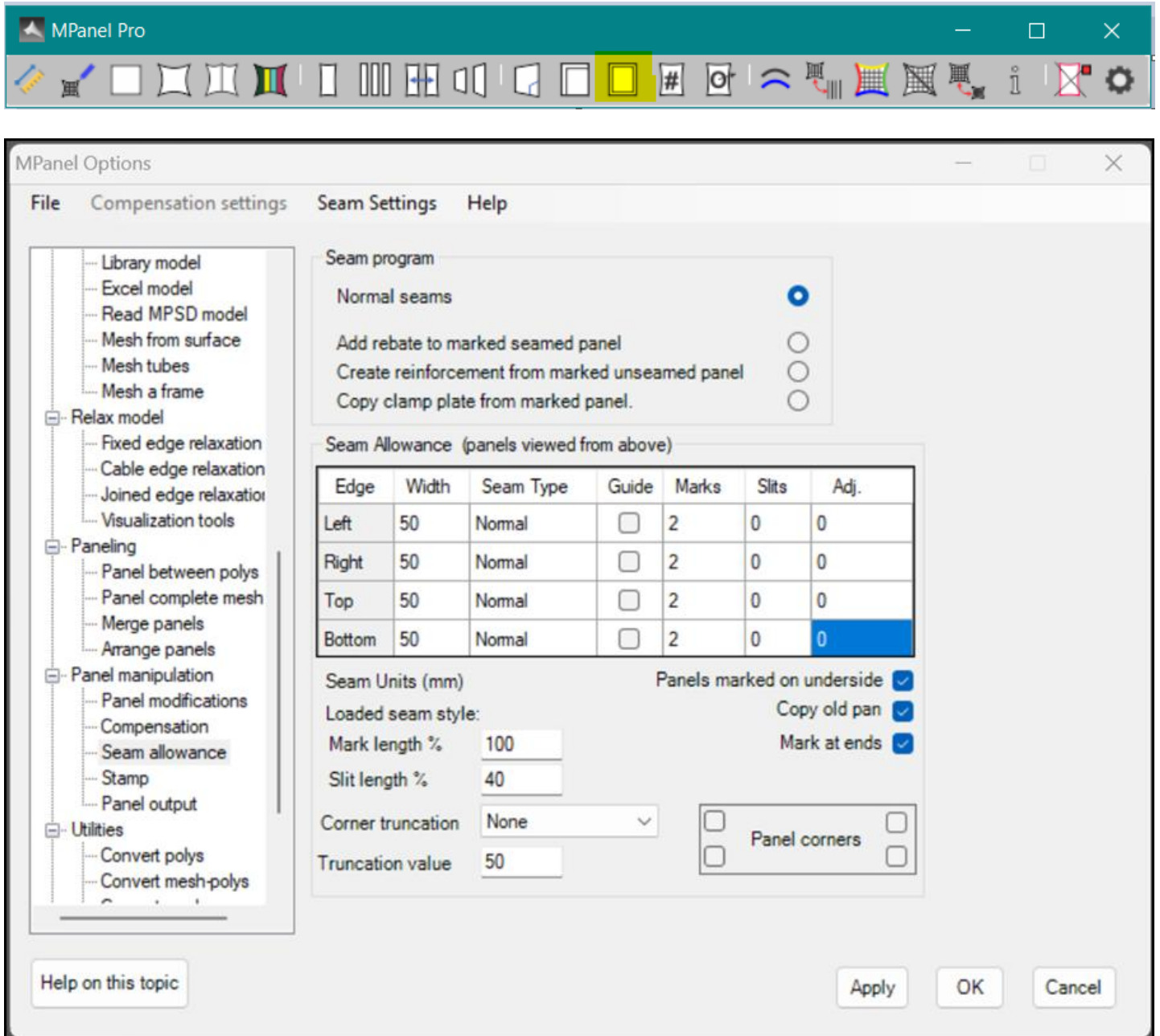

This tool applies the seam allowance values entered in the options to the panel or to a set of panels. The seam allowance is entered in drawing units, ie if you are working in inches, the seam allowance is in inches, if you are working in millimeters the seam allowance is in millimeters.

In addition this tool can also create clamp plates, corner reinforcements, and rebates for cable cut outs from panels that have specially marked detail polys in them. These detail polys are generated by the Model builder tool "Add dimensioned corner"

Normal seams

The seam type can be specified for each edge, and optionally can generate a guideline to align the panel to during assembly. Different types of seams can be specified:

Normal	guideline is the original panel, usable for sewn edges
Lap Over	suitable for the edge on top in a lap seam *
Lap Under	suitable for the edge underneath in a lap seam *
Fold To	guideline to fold back to for a cable pocket
Butt	sets the mark length suitable for a butt seam
Offset	seam for very curved edges where parallel seams don't work
Offset Fold	cable pocket for very curved edges

Triangular used to continue the fabric over a top ring
Mirror used to create a seam that mirrors the panel end shape, so the fold back fits the panel exactly
Square offset used to create an edge such as a valance with square edges

In addition the original panel can be added to the new panel as internal detail.

If the "Panels marked on underside" option is selected then the lap over and lap under options will automatically be swapped making it simpler to plan fabric shingling when viewed from the top view.



Video: [Panels marked on underside](#)

Tick Marks

Optionally, seam allowance can add tick marks, or balance marks to the new drawing. These can be used as a line up aid during production. Usually these are added along the warp, or long edge of the panel, but they can also be added on the top and bottom edges. The tick marks can be specified as:

A Number	like "7", which will generate 7 equally spaced tick marks on the side.
Std	rules for generating standard tick marks will be followed.
Nodes	tick mark is generated at each node along the edge
Detail	tick mark is generated from the centre node of any mark detail in the panel
None	no tick marks

Standard rules can be set under the "Seam Settings" menu item.
The position of the marks will be adjusted according to the type of guideline specified.

When the tick marks are specified by a number you can choose to have them starting and finishing at the panel ends, or starting part way into the panel. Often using marks partway into the panel causes less confusion, as the marks at the ends can be lost with some seam allowances.

Slits

Optionally Slits can be added to any edge. These are usually used on fold to edges to allow the edge to take a curved shape. The slit length is set as a percentage of the seam width. The slits are specified in the same manner as the tick marks.

Each seam edge also has an adjustment column, that will adjust the seam width in or out by a small amount. This has use when making a rope edge or catenary edge, when a fabric allowance is needed to go around the rope, without altering the real seam width.

Truncation

Optionally panel corners can be truncated to avoid wasting fabric on the seam extensions to sharp corners. Individual corners can be specified for truncation. Normally the truncation is made in a straight line cut, but if the panels will be assembled by sewing back to back then it is useful to have an arc truncation. This allows for easy location of the panel corners. The truncation value is the distance back from the reference corner for all but the rebate style which trims the corner back until the corner width is the specified truncation value (e.g. width of the base of a "D" ring).



Video: [Corner truncation - rebate](#)

Seam Styles

You can save any number of named seam styles for future use, by using the "Seam Styles" on the menu bar. So if you had a panel seam arrangement defined for a small cone tent, you could save it as "Small Cone". When you load in a seam style, the style name is displayed alongside the seam table.

If you saved seam styles on versions of MPanel Pro before v13, then the named seam styles will still be available. If you did not name them, they will be named "UnNamed Style 1", etc.

Standard Alignment marks and slits.

Standard alignment marks and slits are defined by the following rule settings:

Distance from start of edge to first mark
Distance from end of edge to last mark
Spacing between the marks
Minimum number of marks.

Standard Panel Warp Direction

Usually the "Standard Panel Warp Direction" checkbox should be ticked, as this forces the program to use a panel warp that lies between the two warp edges, which are marked on the panel in the extended data. This then defines the top, bottom, left, right edges independently of the panel orientation on the screen. In some situations you may want to override this, and use a panel orientation where the top, bottom, left, right edges are as viewed on the screen in top view. You do this by setting Standard Panel Warp Direction = Off, accessed under the 'Panel Tools' tab.

Corner tools

Add rebate to seamed panel

This takes panel with specially marked detail polys, cuts a rebate from the seam to allow space for the cable connection, and truncates the corner. This should be applied to a panel that has a seam allowance already added, and the panel should have 1 or 2 reinforcement marks in place.

Create reinforcement panel

This creates a small reinforcement panel that will fit under the clamp plate, around the rebate marks, and trim to the panel finished edge. To ensure that the reinforcement fits to the panel finished edge this tool should be used on the panel before seams have been added.

Create clamp plate

This creates a prototype outline for the design of a metal clamp plate. It can be derived from the seamed or un-seamed panels. The outer edges of the clamp plate will be joined together in a continuous polyline. The bolt hole marks will be replaced with higher definition polylines representing a circle, with a centre mark.

The clamp will need further design work, including shaping the rear of the clamp plate to accept the connection to the pole. It may be useful to un-group the component parts for this, or to turn group selection on or off in the usual manner. (In AutoCAD with Ctrl Shift A)

Panel Stamp

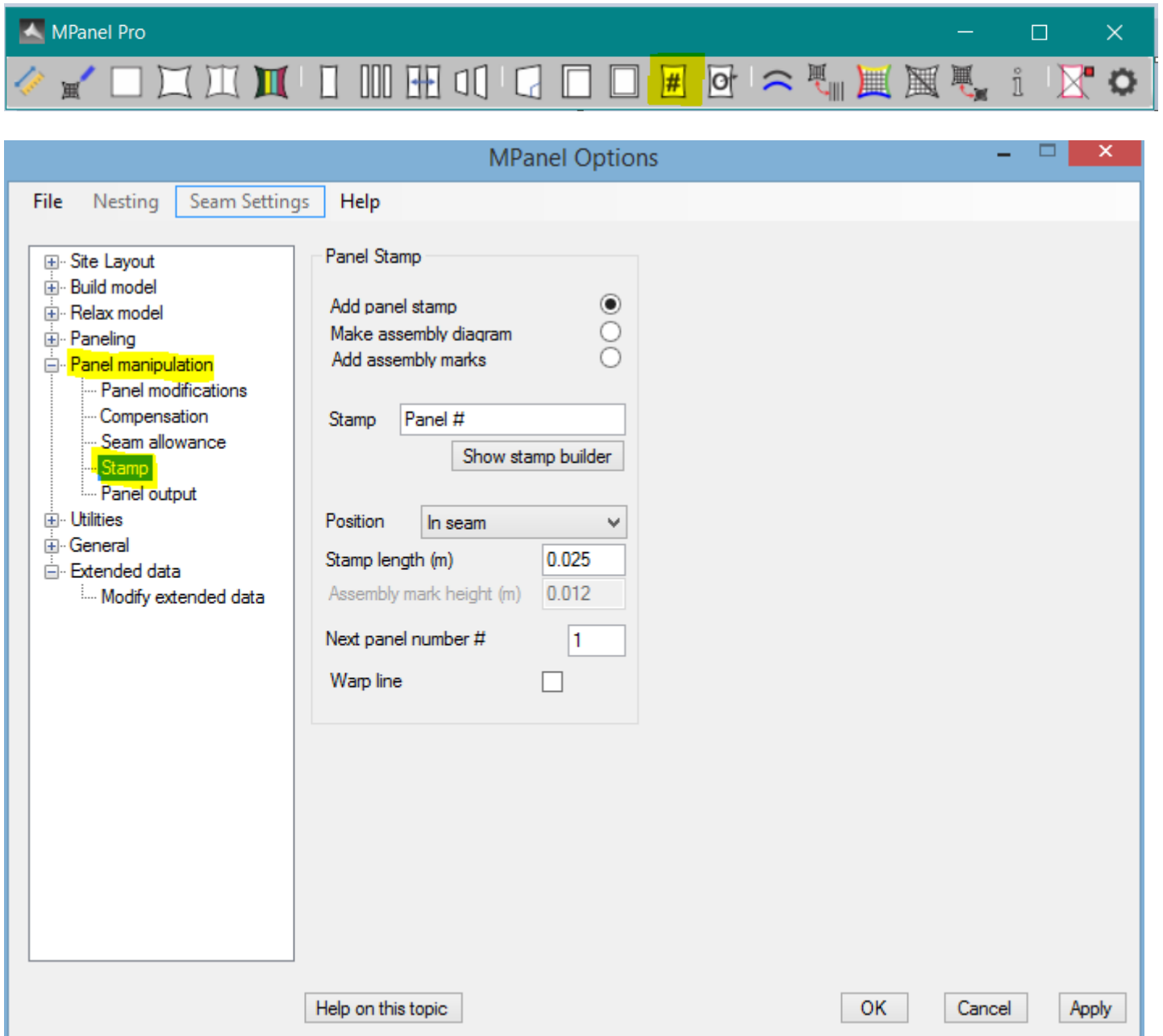

Panel Stamp adds text and lines to the panel to assist with manufacture and assembly. There are 3 functions:

- Add panel stamp
- Make assembly diagram
- Add assembly marks

Add panel stamp

Plots the panel name on the panel in a choice of positions:

Inside the seam, parallel to the bottom panel edge.

Along to the panel centre line

In the middle of the panel

In a cut off tag outside the seam

Optionally a warp line indicating the warp direction of the panel can also be drawn along the panel centre line, near the bottom panel edge.

The warp line is used to indicate the preferred panel orientation on the roll, and is used by [nesting](#) programs and cutter

layout software to control the warp direction.

The warp line can be aligned to the default panel warp (center line of the panel) or to the nearest X or Y axis on the screen.

The length of the warp line is specified as the stamp length, and can be used as a final check that the panel was plotted / cut with no scaling.

The text is scaled to produce a stamp about the same length, even when no warp line is plotted. To force a smaller text size include some blank spaces at the end of the panel name.

The panel name can be based on:

- the unique panel ID number that MPanel Pro assigns to each panel
- a specified number that is incremented with each stamped panel.

The full panel name can be built using the panel name builder, and can be simple or complicated, like:

P1
Panel 1
Job 15-83a Celtic Brown Panel 1

The panel name builder will remember that last used partial names, and optionally can also contain a user supplied list of names from the MPanel Pro User Setting.ini file, in the users documents directory, in the style of:

[STAMP NAMES PART 1]
Stamp 1 = My special panel name
Stamp 2 = Another special name

Make assembly diagram

An assembly diagram is a set of lines showing which panels edges join together. This tool will take a set of panels, arranged approximately as they would be assembled, and draws in a possible set of assembly lines. If the assembly lines are incorrect or incomplete, they can be editing in CAD by drawing simple lines.

The assembly line drawing can be used to indicate panel assembly for production, but it's main use is to define the position of panel assembly marks to be plotted at the next stage.

To get the best possible set of assembly lines arrange your panels so that:

- Panels do not overlap

- Joined edges are close together

 - (close means less than their edge length)

- Centre points of joined edges are approximately square on to each other

 - (square on means that the line will make an angle of more than 45 degrees to the panel edges)

Make assembly mark

An assembly mark consists of text added in the panel seam where an assembly line touches the panel.

The assembly mark is a unique text of the form:

m xxx-yyy

where xxx and yyy are the respective panel ID numbers.

The text height can be directly specified. Usually the panels will be assembled with the two "m" marks lined up.

Assembly marks can be used instead of, or in addition to normal panel stamping.

Panel Output

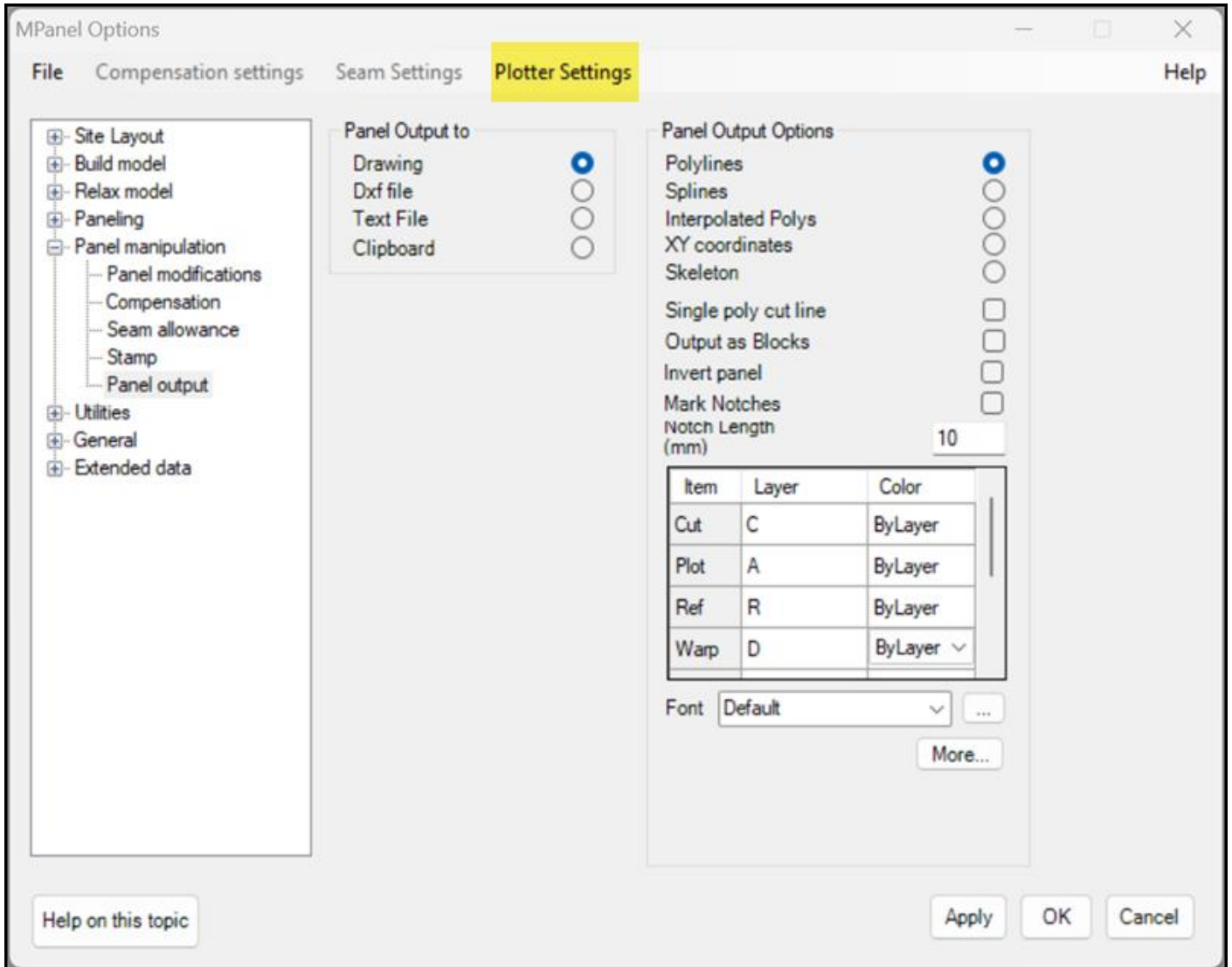

Panel Output takes a drawing of one or several panels, typically consisting of inner and outer polylines, tick marks and identifying text, and makes a copy of the panels in a form that is suitable for direct output to a cutter, plotter, or drawing grid.

The panel output can be to:

- **Drawing** the present CAD drawing
- **DXF file** a specified file in dxf release 14 format (to change version see [General Settings](#))
- **Text File** a specified file in text format
- **Clipboard** the windows clipboard in a format that will paste into spreadsheets correctly.

Plotter Settings:

When outputting to a dxf file the user can select any combination of settings to suit a wide range of plotting machines. The Plotter settings option includes settings for some plotter machines with known settings.

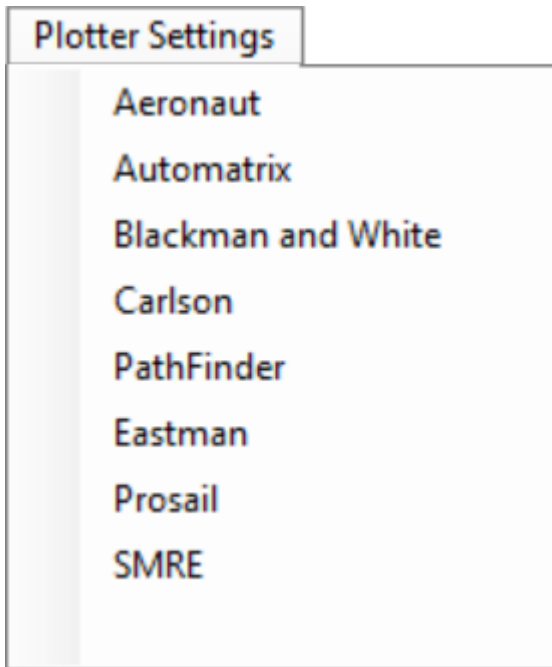

The output type can be:

Polylines

A copy of the original polylines. Optionally they can be joined together into a single polyline per panel. Optionally tick marks can be converted into notches, cut into the edge, of a specified length. Optionally the panel can be drawn as a block. The drawing entities will be separated onto layers as defined by the layer table.

Splines

A spline is drawn through the nodes of the original polylines. Optionally the panel can be drawn as a block. The drawing entities will be separated onto layers as defined by the layer table.

Interpolated polylines

An new polyline is drawn for each edge, based on the spline that would pass through the nodes of the original polylines. Optionally they can be joined together into a single polyline per panel. Optionally tick marks can be converted into notches, cut into the edge, of a specified length. Optionally the panel can be drawn as a block. The drawing entities will be separated onto layers as defined by the layer table.

XY coordinates

The XY coordinates of the edge nodes are generated in the specified format. Fractional inch formats are supported, as well as decimal inch and settings suitable for metric measurements. A minimum X value can be specified to give a offset from the roll edge for the panel. If the output is to the drawing, a copy of the panel will also be drawn, with the node numbers marked.

Skeleton Panel

A line outline of the panel is drawn, with each edge having its length, and the dip of the edge curve from the line mid point specified. This can be used for panel checking, or can be used to generate by hand the edge curves for simple panels.

Colors and Layers

Normally all output is drawn with the color set to 'By Layer'. This lets you assign different colors to the output layers, to see that the panel is correctly split into the different layers. If you need to suppress a layer, just give it a blank layer name.

The panel entities will be separated onto different layers. the default layer names are:

Cut curve	Layer C
Annotation	Layer A
Lineup marks	Layer D (drill)
Warp Line	Layer G (grain)
Reference	Layer R
Slits	Layer I
Text	Layer A

Use of the above features creates panels that comply with the AAMA specification for DXF output.

Additionally the color can be set individually for each layer. This has use if the cutter / plotter you are uses colors rather than layers to define the actions of each layer.

Fonts

Normally the stamp text font is not specified. This allows the cutter / plotter to use it's preferred font, and should result in high speed plotting of the text. With some cutter / plotters it is better to specify the font, which can be done in the options. The font specified should be one that is available to the plotter / cutter. Usually the font can be selected from the windows font table. Non window fonts (such as the AutoCAD shx fonts) can be specified by pre-pending an asterisk. So *txt will specify the AutoCAD font txt.shx, if that is available on the cutter plotter.

Some cutters are slow when drawing text. Specifying "MP vector font" substitutes polylines for the text outlines, and can offer a useful speed increase.

Mark Targets

Some cutters require mark targets, small solid circles that are used to maintain alignment during sheet movement, especially on conveyor plotters. These can be added at each panel mark, with a specified radius and offset from the panel edge. In the drawing they will show as hollow circles, they are filled in during the dxf export. The targets are turned on by non zero value for the radius.

Outline

Some graphics operations require a bleed outline, that an image is drawn to before the panel is cut out. The outline can be specified by an offset distance from the panel. The bleed outline is turned on by non zero value for the offset.

Convert PolyLines

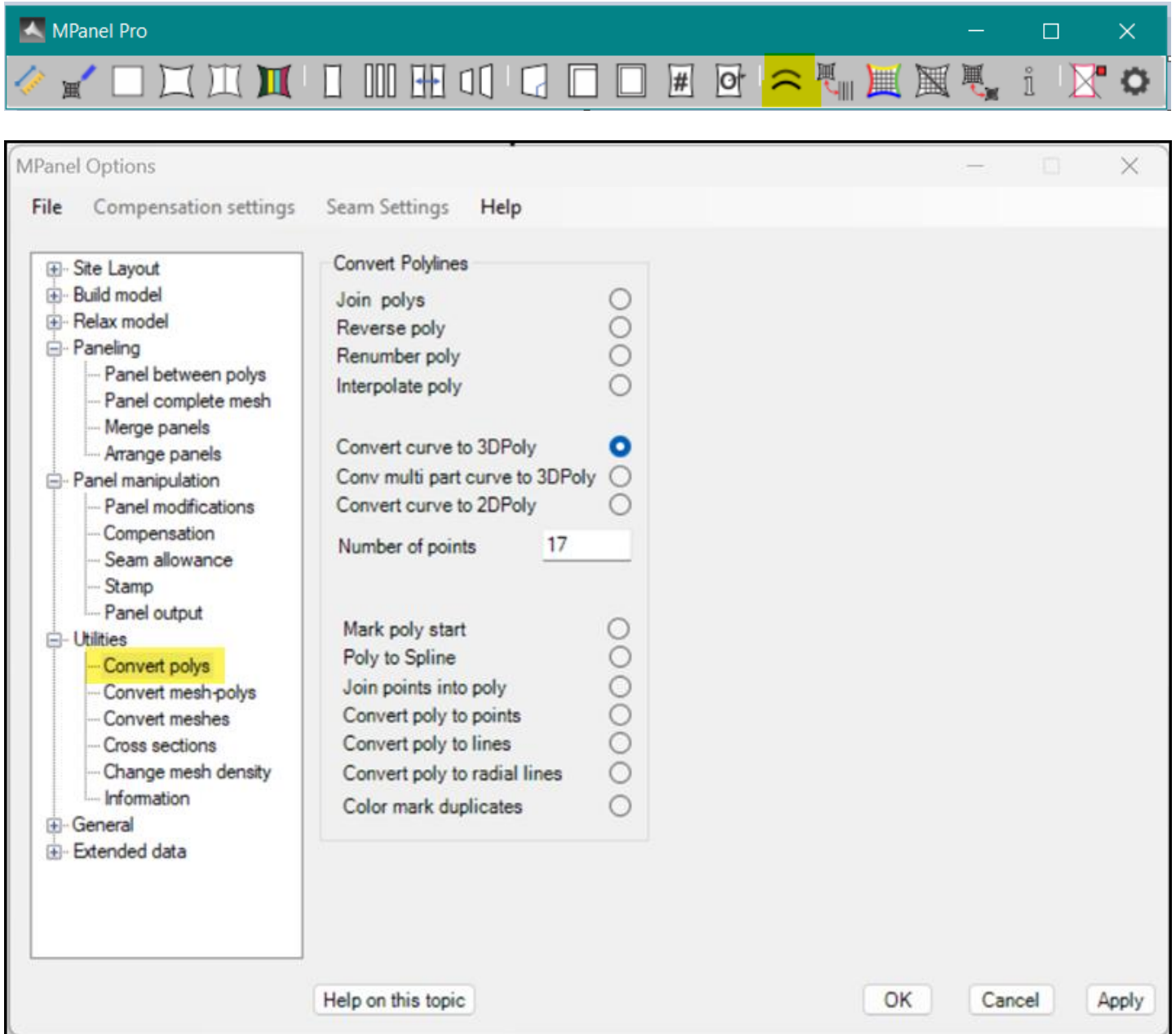

Convert polylines can perform different operations on 3Dpolys.

Join Polys:

Will join any number of 3D polylines together. The direction of the new polyline is the same as the direction of the largest 3Dpoly selected for joining. If the joined 3Dpoly makes a closed figure, then the start and end of the joined 3Dpoly will be the start of the first 3Dpoly selected for joining. If there are gaps between the polys you will have the option to:

use an average point in the middle of the gap.... this is the usual method

fill the gap with an extra polyline section

use a point created by the intersection of the polylines.... used to create a corner when it wasn't possible to take the poly into the corner, eg with digital measuring equipment.

Convert curve to 3dPoly:

A polyline with embedded arcs, arc, circle, ellipse, elliptical arc, line or spline will be converted to a 3Dpolyline. The number of points in the 3Dpoly is set in "Num Points". This tool has particular use as many MPanel Pro tools require 3D polylines for input. Supports multiple conversions at the same time.

Convert multi part curve to 3dPoly:

A series of lines, curves, arcs, etc that are separate entities but with coincident ends so that they look like a single entity, will be converted to a 3Dpolyline. There is guaranteed to be a 3D polyline node at each curve end, and the remaining points are evenly distributed between the entities. Multi part curves are often created by digital measuring software, and

this provides a convenient method to convert them to a 3Dpoly whilst preserving the "corners" at the ends of the entities.

Reverse Poly:

Will reverse the direction of a 3D polyline. Supports multiple 3Dpolys at the same time. Will also work with lines.

Renumber poly:

Will redraw the 3D poly with the specified number of points. If there is a sharp corners in the 3D polyline then a node will be placed on that corner. More tan 1 sharp corner will generate a warning. Supports multiple 3Dpolys at the same time.

Interpolate poly:

Will redraw the 3D poly with the specified number of points. The points will be spaced along a spline that runs through the original points. In general this will give a better shaped 3Dpoly than "Renumber 3Dpoly", as long as the original 3Dpoly was smooth. Supports multiple 3Dpolys at the same time.

Convert to 2Dpoly:

A 3Dpoly, polyline with embedded arcs, arc, circle, ellipse, elliptical arc, line or spline will be converted to a polyline. The number of points in the poly is set in "Num Points". The Z elevation is set to zero. This tool has particular use when adding panel detail, as MPanel Pro require polylines panels. Supports multiple conversions at the same time.

(In AutoCAD, the 2Dpoly is drawn as a LWpolyline)

(In Rhino, the 2Dpoly is drawn as a polyline, with the Z value of each point set to zero)

Mark poly start:

A marker triangle will be drawn at the start of each poly, to show it's direction. This is useful when making cross sections into panels or meshes.

Will also work with lines.

Poly to Spline:

A 3DPoly will be converted to a spline. It has use when outputting lines with a small number of data points, but requiring a smooth curve.

Join points into Poly:

Takes a set of points and joins them together into a polyline, on the basis that the closest points as joined together. Generally this method will give an acceptable poly, but it is possible for loops or kinks to form when the point spacing varies.

Convert poly to points:

Will convert a 3D polyline into a series of evenly spaced points based on the specified number of points. This is ideal for adding [detail](#) to panels

Convert poly to lines:

Will convert a 3D polyline into a series of lines which is useful when adding a belly or valley cable.



Video: [Diagonal Cables](#)

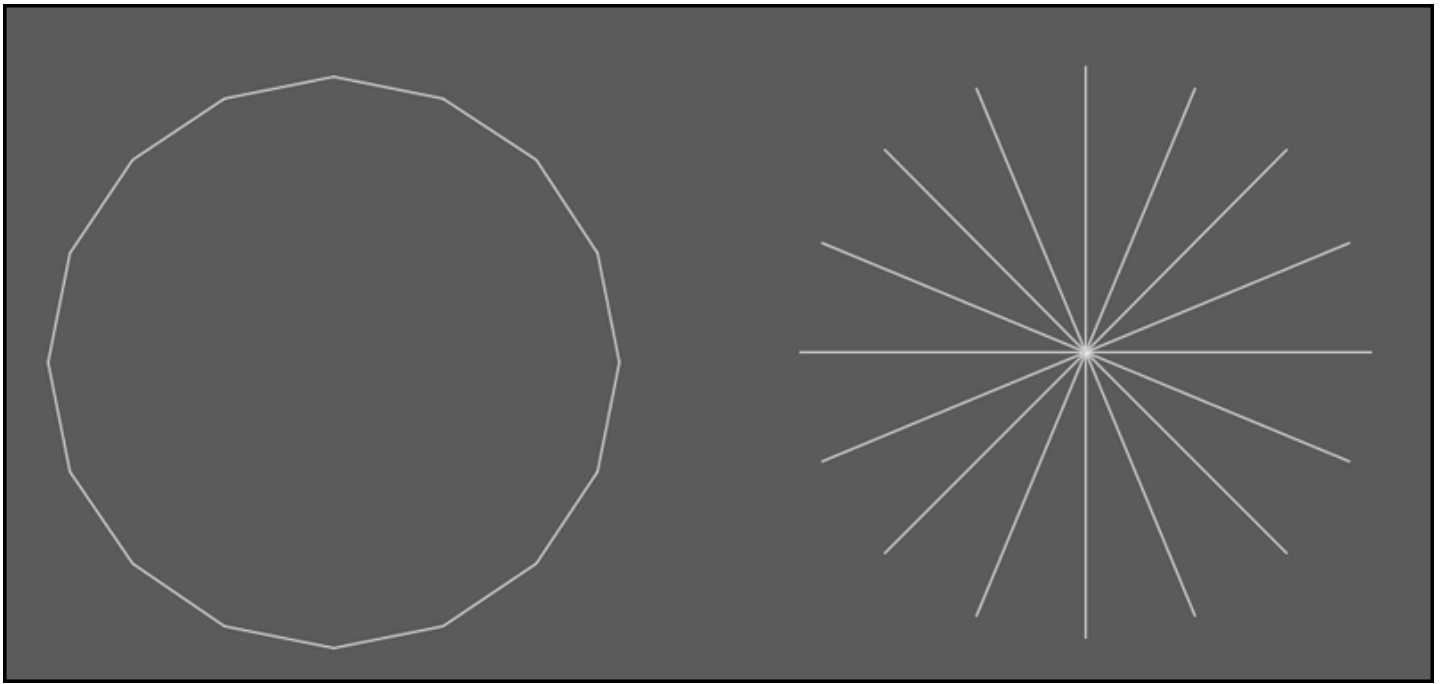

Convert poly to radial lines:

Will convert a circular 3D polyline into a series of lines which is useful for modeling linked elements used in FEA analysis.

Color mark duplicates:

This takes a set of polys, and marks for deletion (Red) those that are exact duplicates. (duplicate polys can arise when making cross sections for paneling). After identifying duplicates simply click "delete old" as usual in order to remove them.



Video: [Color mark duplicates for deletion](#)

AutoCAD Note:

Although the tools are designed to work primarily with 3dpolys, the following tools will also work with 2dpolys (called polylines or LWpolylines in AutoCAD)

- Join polylines
- Reverse polylines
- Renumber polylines
- Interpolate polylines
- Poly to spline
- Mark poly start.

However in reading the 2dpolys the following restrictions apply:

- Elevation is ignored
- Polyline OCS is ignored
- Embedded arcs are ignored

In Rhino there is no difference between a 3dpoly and a 2dpoly, so this section does not apply to Rhino users.

Convert Mesh/Polylines

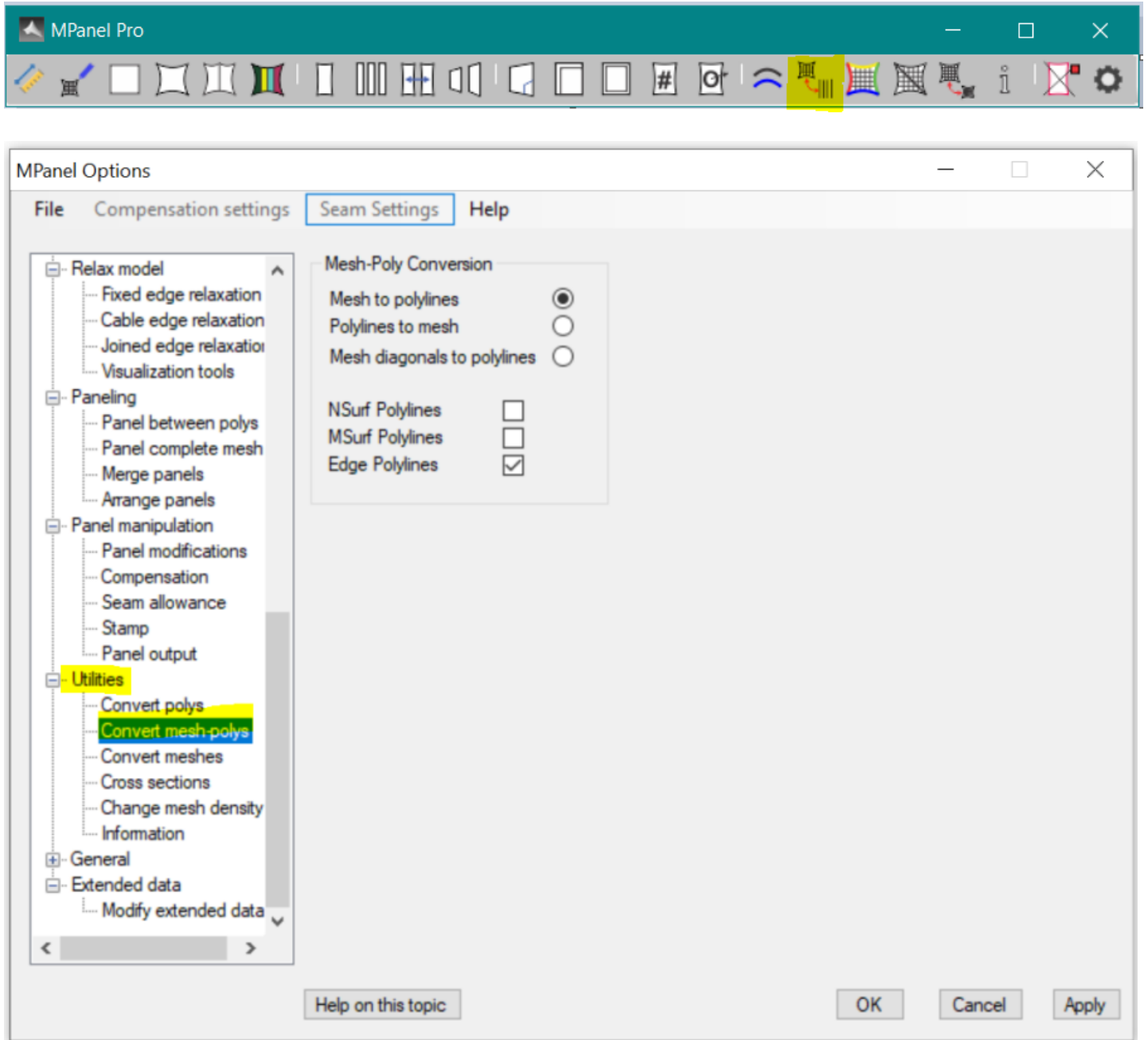

Convert Mesh/Polylines can perform these functions:

- Convert Meshes into Polylines
- Convert Polylines into meshes
- Convert mesh to diagonal polylines

Convert Meshes into Polylines

Will convert a mesh into a series of 3D polylines. Either the Nsurf, Msurf, or the Edge polylines can be drawn. This tool will work on multiple meshes, and any duplicate polylines are suppressed. Optionally the polylines drawn can be grouped together.

Convert Meshes to diagonal Polylines

Will convert a mesh into two diagonal 3D polylines. This tool is useful for adding belly and valley cables to a mesh. The diagonal poly should be added to the original mesh then using the Convert poly to lines.



Video: [Diagonal Cables](#)

Convert Polylines into meshes

Will take a group of 3D polylines and convert them into a Mesh. If the mesh is too 3D curved, the polylines may be meshed in an incorrect order. The solution to this is to create 2 or more meshes, each of which will sort out it's polylines correctly, and then use the Join Meshes command.

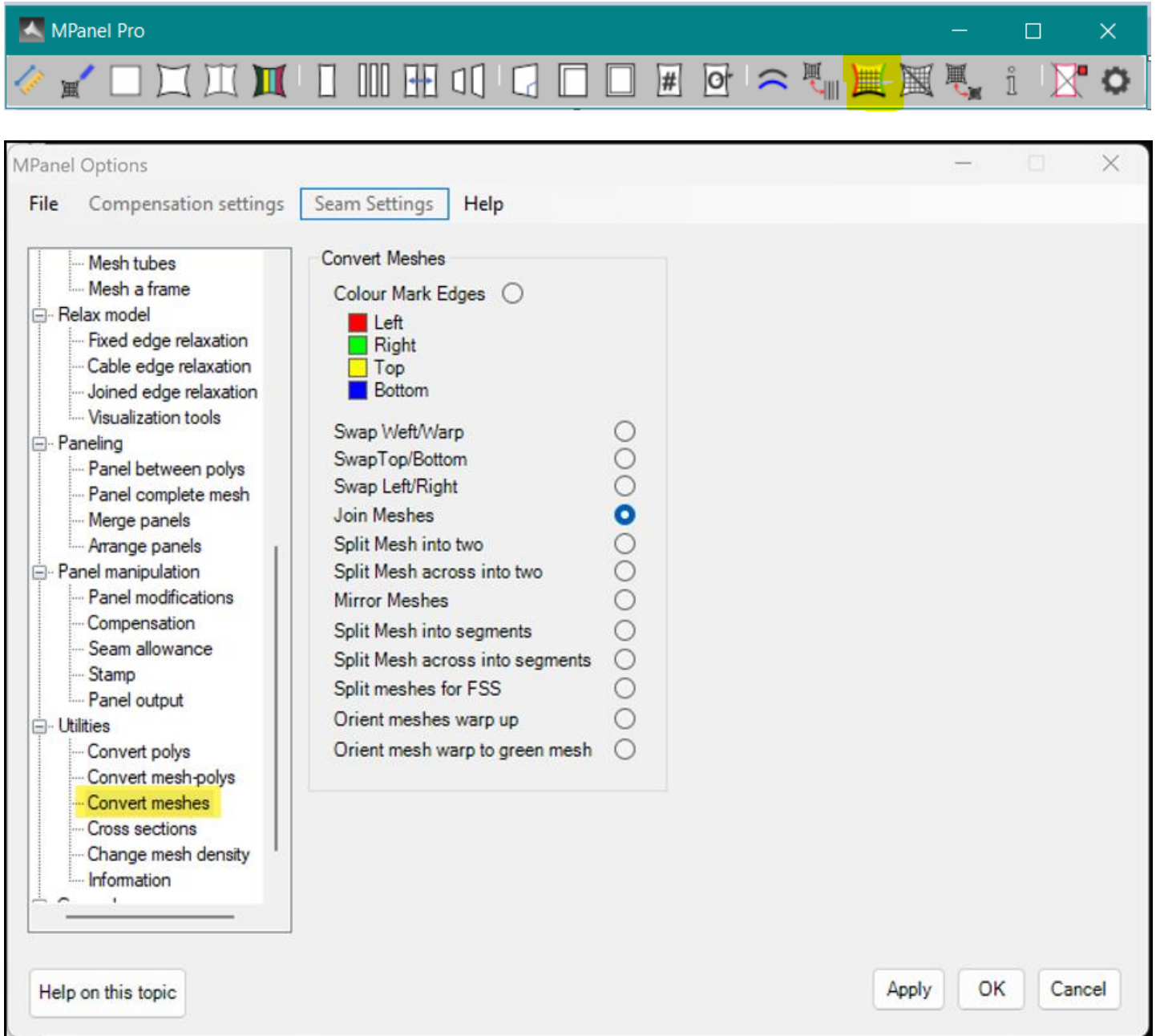

Convert Meshes is a modeling tool that can report and alter the orientation of meshes, helping to get consistent model orientation, and offering a different direction to panel in. The tool can perform the following functions:

- Color Mark Edges
- Swap Weft and Warp
- Swap Top and Bottom
- Swap Left and Right
- Join Meshes
- Split Meshes into two
- Split Meshes across into two
- Mirror Meshes
- Split Mesh into segments
- Split Mesh across into segments
- Split mesh for FSS
- Orient meshes warp up
- Orient mesh warp to green mesh

Color Mark Edges

This will take any number of meshes, and draw a colored outline just inside the mesh. This allows inspection of a model

to see if the meshes are oriented correctly, and it can identify edges to determine which edge a cable is on. The color coding is:

Red Left edge
Green Right edge
Yellow Top edge
Blue Bottom edge

Swap Weft and Warp

Will redraw the mesh with the weft and warp directions swapped. This has particular use when you want to panel a complete mesh along the "Mesh weft" direction.

Swap Left and Right

Will redraw the mesh with the left and right edges swapped

Swap Top and Bottom

Will redraw the mesh with the top and bottom edges swapped

Note: Extended data that existed on the meshes is preserved by all the "swap" options of this tool, so special settings for weft/warp stress ratio, or cable tension ratios, will be preserved.

Join Meshes

Will take a set of meshes with common edges, and if possible redraw them as a single mesh. This has use in recreating meshes, and in making whole model meshes that look smoother in renderings and visualisations. If possible the original mesh warp direction is preserved.

From version 25 on the "Join meshes tool" now allows joining meshes with different mesh density. Note: This feature requires a mesh interpolation which may cause a small change in the surface shape, a warning is displayed when the tool is used.



Video: [Join mesh with mixed mesh density](#)

Split Mesh into two

Will take a mesh and split it into two meshes, either in the N or M mesh direction. If the number of mesh threads in the selected direction is an odd number, then the mesh will be split exactly into 2 meshes. If the number of threads is even then one mesh will be larger than the other,

Split Mesh across into two

Will take a mesh and split it into two meshes in the opposite direction to the previous tool.

Mirror Mesh

Will take some meshes (and 3dpolys and lines if selected with the mesh) and mirrors it/them while keeping the correct mesh orientation - this command should only be used once to a mesh. (Note Both AutoCAD and Rhino fail to mirror meshes correctly with their own mirror routine).



Video: [Mirror mesh](#)

Video: [Mesh naming](#)

Split Mesh into segments

Will take a multipart mesh and break it into individual mesh segments. One example use of this tool is to break a [tube mesh](#) into segments.

Split Meshes for Framed Shade Structure (FSS)

Will automate splitting 4 selected meshes from an FSS into 2. The 2 end triangle meshes are split into 2 and then each half is joined to each rectangular mesh to make 2 single meshes (shown below red and yellow) which are ready to be panelled into 2 flat panels.

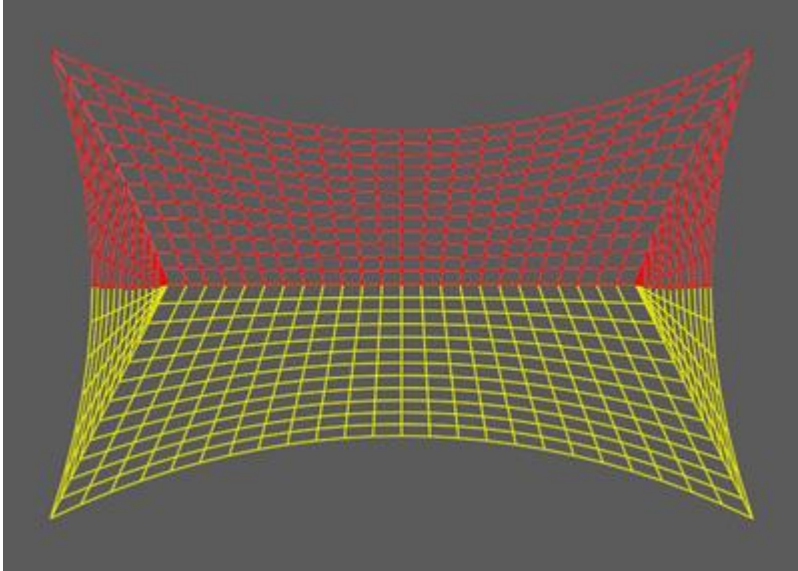

Orient meshes warp direction up (+Z)

Will automate orienting all selected meshes warp direction up so the lowest mesh edge (in 3D) will become the bottom mesh edge and warp direction will align toward the top mesh edge (in 3D). This is useful in models with many meshes in different 3D planes.

Orient meshes warp direction to match green mesh

Will automate orienting all selected meshes warp direction to be the same as a "reference" green mesh. Simply choose a mesh and colour it green - this becomes the "reference" mesh. All other selected mesh warps will align with the reference mesh. This is useful in models with many meshes in the same 3D plane.

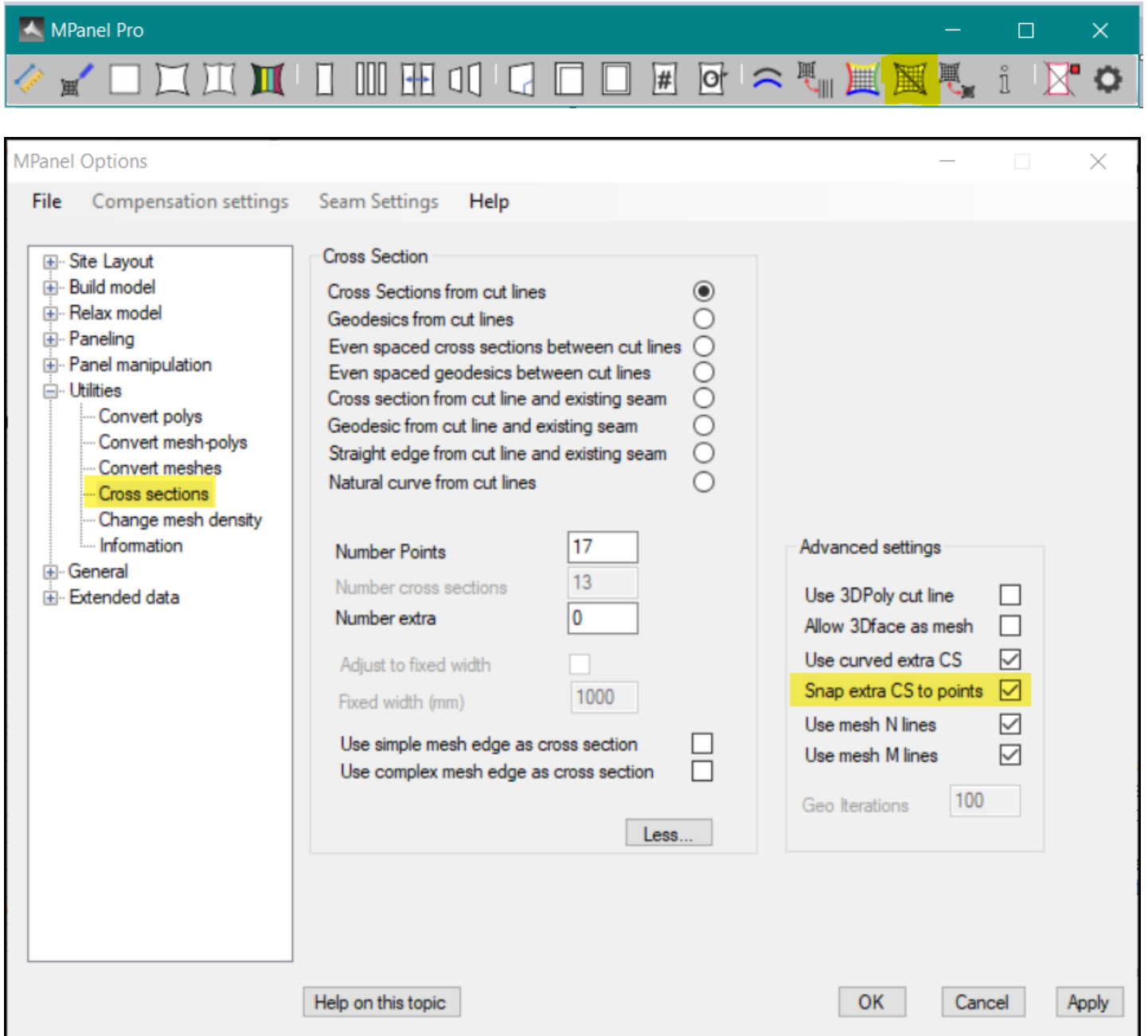

Cross Section can be used to make cross sections across several meshes, that can be used for panel seams, building new meshes, or drawing lofting curves. It can perform the following functions, as set in the options:

- Cross Sections from cut lines
- Geodesics from cut lines
- Even spaced Cross sections from cut lines
- Even spaced Geodesics from cut lines
- Cross section between cut line and existing seam
- Geodesic between cut line and existing seam
- Straight edge from cut line and existing seam
- Natural curve from cut lines

with further modifying options of:

- Use mesh edge as cross section.
- Add extra cross sections
- Fixed spacing

and more advanced settings are available with the More... button

Cross Section from cut lines

Cross Section takes any number of lines as cutting lines, and drops an imaginary vertical plane down from the lines through any number of meshes. This is usually achieved by viewing the meshes and polylines from above in XY view, and drawing in the cutting lines. The cutting lines and the mesh(s) are selected, and the cross section tool run.

If the number of cross section points is not specified, the tool will put in as many as possible. If the number is specified, they will be evenly spaced between the cross section points. The cross sections will be pointing in the same direction as the cut line.

Cross Section will create the cross sections as 3D polylines. These cross sections can be used as panel seams, lofting lines, or polylines to build new meshes from.

If the cross sections are close to a mesh edge, you should visually check the result to ensure that the cross section is inside the mesh. The program does not check for this.

The start of the cross section is the point in the mesh closest to the cut line start, similarly with the end. In heavily curved cross sections you may have to adjust the z value of the cut line ends to obtain the required cross section.

If a cut line lies directly over a mesh edge, optionally the mesh edge can be used instead of the cross section.

Extra cross sections can be specified that will be spaced between the supplied cut lines. These extra cross sections will normally be curved to fit between the main cross sections.

Geodesic

Geodesics are curves whose end points are defined by the cutting line and the meshes, but whose inner points follow a geodesic line across the meshes. This is achieved by allowing the line to relax in the meshes. This can produce lines that are useful for paneling difficult shapes with a minimum of material wastage.

There can be any number of lines as cutting lines, across any number of meshes

The number of points in the geodesic line is set in the options. You should visually check the result to ensure that the geodesics near the mesh edges have stayed inside the mesh, the program does not check this.

The starting curve for a geodesic is the cross section, so your cut lines should be able to define a good cross section to obtain a valid geodesic.

If a cut line lies directly over a mesh edge, optionally the mesh edge can be used instead of the cross section.

Making geodesics is an iterative procedure, the number of iterations is set in the Advanced options.

Extra cross sections can be specified that will be spaced between the supplied cut lines. These extra cross sections will normally be curved to fit between the main cross sections.

Even Spaced Cross sections or Geodesics.

This creates a set of cross sections that are spaced between two cut lines. The number of cross sections produced is specified in the options. The spacing is adjusted so that the panels produced from the cross sections would be the approximately the same widths, ie the cross sections are evenly spaced in the 3d model. The width achieved is reported in the text window

The start and finish points of the cut lines for the intermediary cross sections lie on direct lines between the start and finish points of the two supplied cut lines. In some cases this means that the supplied cut lines need to be extended, to ensure that the full mesh is caught by the intermediary cut lines.

If one of the two supplied cut lines lie directly over a mesh edge, optionally the mesh edge can be used instead of the cross section.

Extra cross sections can be specified that will be spaced between the evenly spaced cross sections. These extra cross

sections will normally be curved to fit between the main cross sections.

Cross sections or Geodesics between a cut line and an existing seam.

This creates a set of cross sections that lay between an existing cross section and the cut lines. This can be used to make the "last" set of cross sections to a mesh edge when making cross section sets one at a time.

you can specify fixed spacing, which will create fixed width panels. The method is to select the meshes, an existing 3Dpoly that is a seam, and a cut line that is in approximately the correct position for the next seam. Specify the required panel width as the spacing. When the tool is run the cut line will be adjusted to produce a new seam poly that will have the correct spacing; so when you panel between the old and new seams the panel width will be close to the spacing figure.

This procedure is then repeated to produce the next seam. The panel width produced will be more accurate if the cut line is in approximately the correct position.

Extra cross sections can be specified that will be spaced between the supplied cut lines. These extra cross sections will normally be curved to fit between the main cross sections.

Straight Edge

Straight Edge is used to assist in creating panels on which one seam will be a straight edge. The method is to select the meshes, an existing 3Dpoly that is a seam, and a cut line that defines the intended seam position. When the tool is run the new cross section will be adjusted to achieve a seam that will give a straight edge on the cut line side of the panel., the other edge will be curved.

This has use with some coated fabrics, where the coating is left of a strip on the roll edge to allow good material welding.

This procedure is then repeated to produce the next seam, using the new seam as the existing 3Dpoly for the next seam.

Straight edge can be used with Fixed Spacing and with Extra Cross Sections.

Natural cross sections

Natural cross sections make curved cross sections, defined by a cut line and a mesh, that mimic the path of the threads in the mesh. If the cut lines coincide with thread ends then these make cross sections with the same curved path as the "Panel a complete mesh" tool. This results in aesthetically pleasing seams, with each seam echoing the mesh shape.

Cut line direction warning

If adjacent cut lines in a set are pointing in different directions then the cross sections will also be pointing in different directions. This will give difficulty in paneling, as the paneling program will generate a "twisted" panel. A warning message is given in this situation.

Options

Use mesh edge as cross section

A simple mesh edge can be used as a replacement to a cross section. Draw a cut line that exactly passes through the mesh corners, and the mesh edge will be used in place of the cross section. The mesh edge poly will have its number of nodes adjusted to the cross section number of points, and the direction changed to agree with the cut line direction.

A complicated mesh edge can be used as a replacement to a cross section. Draw a cut line that exactly passes through some mesh edge nodes, possibly on different meshes. The shortest path between the mesh edge nodes over all the mesh external edges, will be used in place of the cross section. The mesh edge poly will have its number of nodes adjusted to the cross section number of points, if there is a sharp bend in the mesh edge poly a node will be placed on

the bend, and the mesh edge poly direction is forced to agree with the cut line direction.

Extra cross sections

Extra cross sections are used to improve the panel shaping by forcing the panel shape to pass through internal cross sections as well as the edge cross sections. They are drawn out in grey, and are curved to fit between the edge cross sections.

A set of cross sections, including extra cross sections, can be paneled in one operation using the "Panel a colored set of polylines" tool

Advanced Options

Use 3dpoly as cut line

To create more complicated cross sections, it is possible to use a 3Dpolyline as the cutting line. This allows the creation of pseudo curved cross sections, when viewed from above. This method can also help to make cross sections to fill the gap between a curved mesh edge, and the first straight cross section.



Video: [3D Poly add details such as zipper to mesh](#)

Allow 3Dface as mesh.

It is also possible to use a set of 3Dfaces as the mesh that the cross section is based on. These are usually produced when a model is imported into the CAD program. This can allow paneling or further modeling on non MPanel Pro geometry.

(In AutoCAD a polyface mesh can then be exploded into a set of 3dfaces)

(In Rhino any irregular mesh can be used as a set of 3Dfaces)

Use curved extra cross sections

Extra cross sections will normally be curved to fit between the main cross sections. This is an option to use straight extra cross sections instead.

Snap extra cross section to points

This forces the extra cross section closest to a point to be moved over to that point. Points are added to the mesh using a standard AutoCAD or Rhino point. A good example of using this would be a 5-sided sail, paneled as one panel, would have the point added on the 5th corner to ensure that an extra cross section goes through it.



Video: [Snap extra cross section to points](#)

Use mesh N lines

Use mesh M lines

Normally all the mesh threads (N lines and M lines) are used to find intersections with the cut lines, to create the cross section. In some situations it is useful to restrict the intersection to only NLine or Mlines.

For example, when radially cross sectioning a conic, using only the MLine intersections will create a cross section that

more closely follows the mesh surface. By also specifying the number of points as zero (which turns off the interpolation routine) this can give cross sections that will make a large panel with a rather lower shear strain than the usual method.

Geo iterations.

Making geodesics is an iterative procedure, the number of iterations is set here, Usually 100 is sufficient, more may be needed if the geodesic is very curved, or has a lot of vertices.

Change Mesh Density

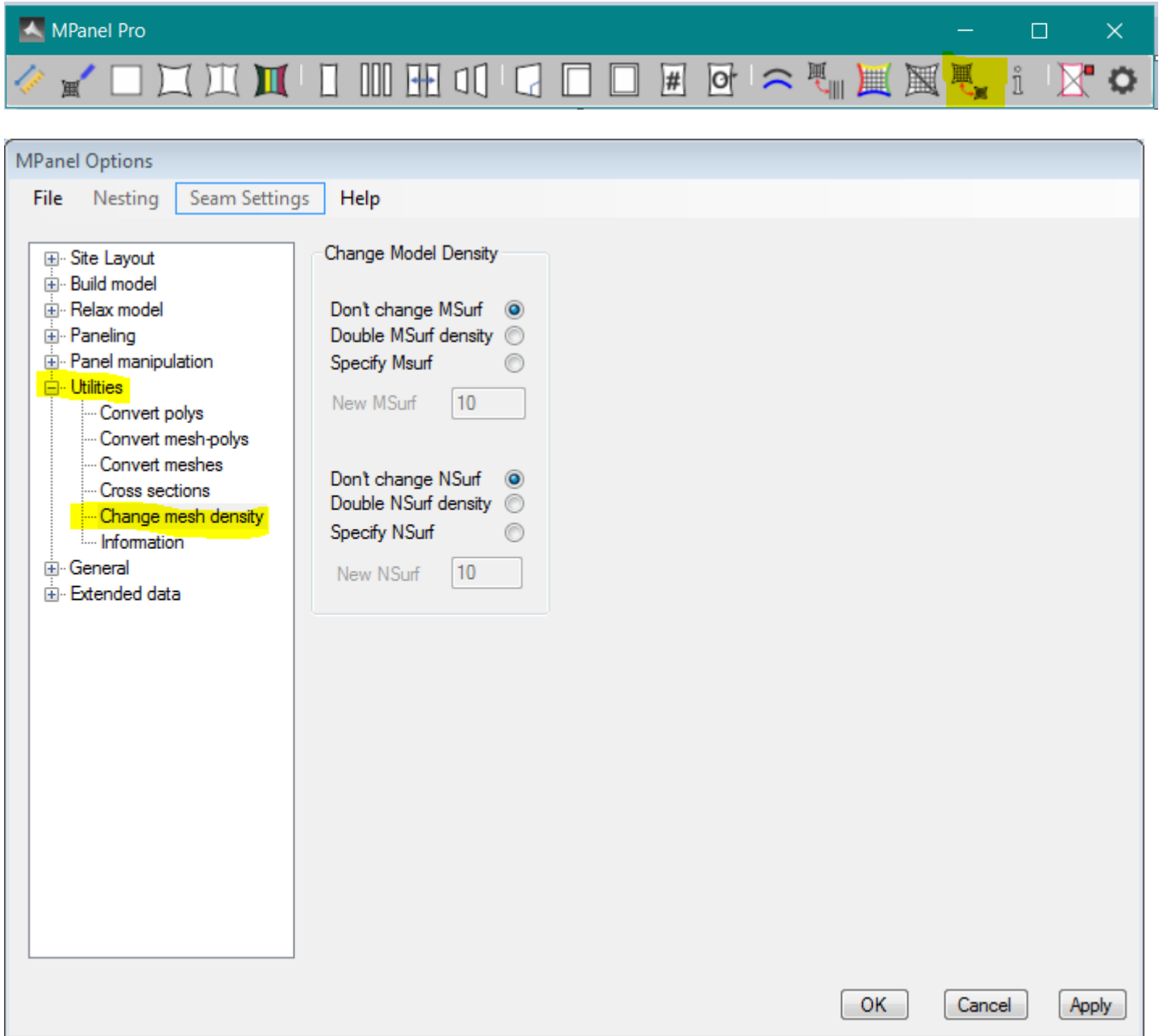

Video: [Change mesh density](#)

Change Mesh Density is a model building tool that can greatly reduce the time it takes to create a high definition model, and can also help to get the right density meshes for direct paneling.

Change Mesh Density can take any number of meshes and double their mesh msurf and nsurf density. This can be applied repeatedly to achieve high density meshes. Note that the high density meshes are created by mesh interpolation, so they will need to be relaxed again to smooth them out. (Technically by doubling the msurf density, the msurf is changed to $2 * msurf - 1$, and the same for nsurf.)

Optionally, you can change the mesh nsurf and msurf to any specified values. This allows more control over mesh density changes. In particular it allows models to be rebuilt to suit a certain number of panels.

If there is a 3Dpoly on the mesh edge, the number of nodes on the 3Dpoly will be adjusted to suit the new mesh by interpolation.

If the 3D polys that are attached to the mesh edges can be recognized as circles or arcs, a new 3Dpoly is drawn with the correct number of points based on the arc. This maintains the models boundary shape when the boundaries are part of a circular arc. The arc can be in any orientation. This will help when altering the mesh density on cone tent models with a split top ring.

A mesh that is attached to a polyline will remain attached to all the polyline nodes during this interpolation.

The result of this is that you can draw your models very crudely, using say 2*3 meshes, with a minimum amount of snapping needed to build the model. You can relax the model, check it, and then apply the Change Mesh Density tool to the whole model to increase the definition. The new model can now be relaxed again.

Extended data that existed on the meshes is preserved by this tool, so special settings for weft/warp stress ratio, or cable tension ratios, will be preserved.

Note: The method used for generating the new mesh is a linear interpolation of the old mesh, and makes no attempt to smoothly follow a curved surface. For this reason the model must always be relaxed again, to get a good surface to panel from.

Information Button

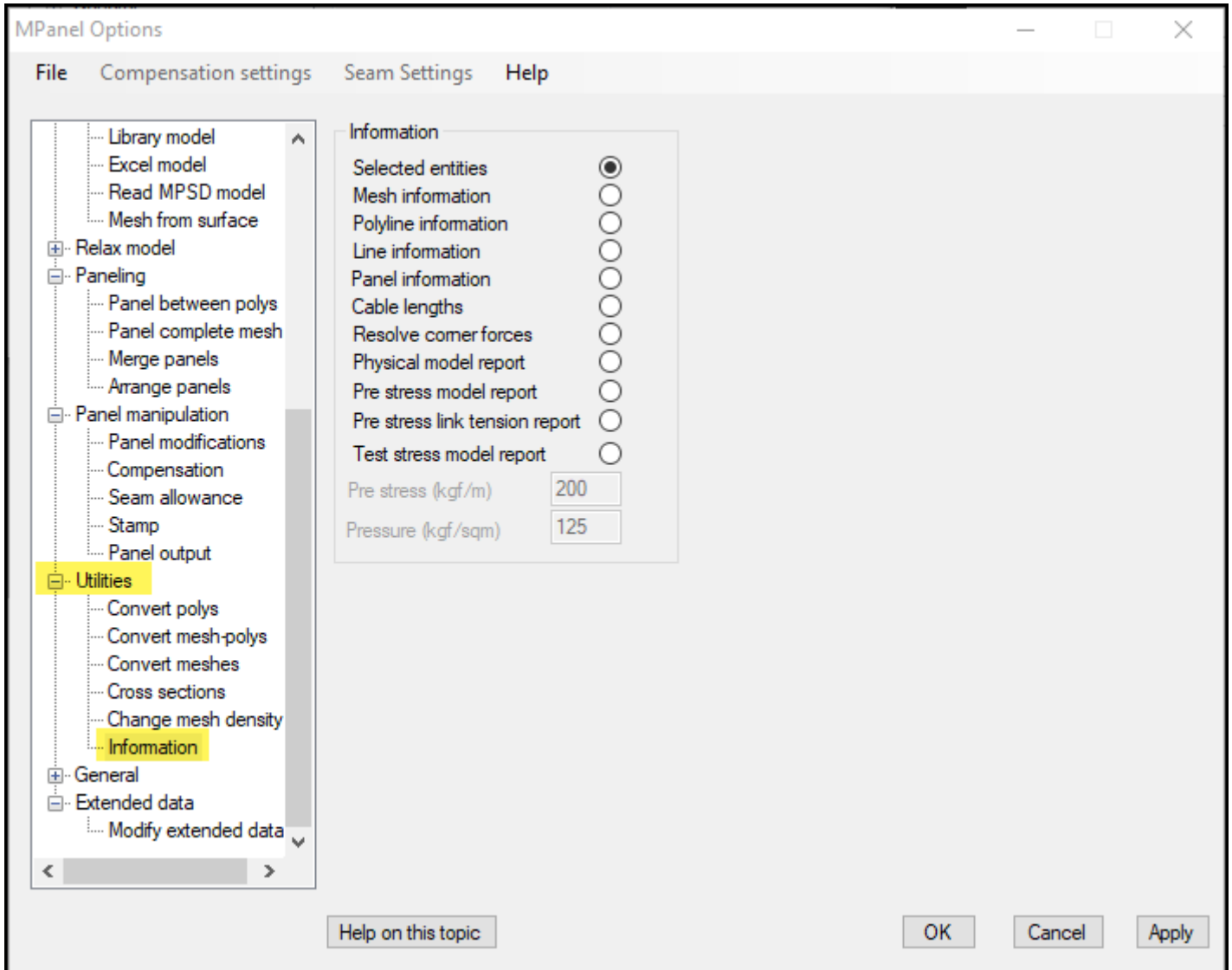
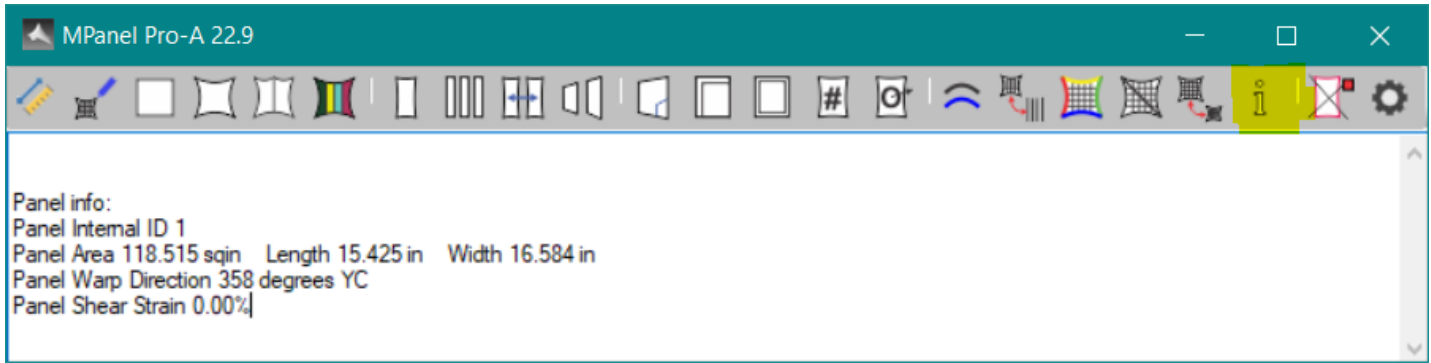

The Information button supplies information about entities that is not easily obtained from the CAD program. The information available is:

Drawing Entities

A list of the number of each kind of entity found is shown. This is useful if you are checking a model: you may know that your model has 4 meshes and 2 3Dpolys, but if the info tool also reports some lines, points, text, etc, you could be accidentally selecting some other entities as well.

Mesh

Area, calculated for the 3D shape of the mesh. This has use in estimating membrane material usage. The area is reported in the default units specified in MPanel, No checks are made on the actual drawing units.

Warp Direction, reported as the degrees clockwise from the Y-axis (like a compass). For example, a mesh direction of 90 degrees means that the top of the mesh is on the right of the screen when viewed in XY. This affects the warp/weft stress ratio, the panel seam direction, and the compensation direction.

The mesh Nsurf and Msurf are reported.

The two minimum radius of curvature is reported, along with the direction of the smallest. This is useful when making stress estimations.

3D Poly

Length. This has use in estimating cable lengths.

Mean Radius, calculated by fitting an arc over the end points and the mid point, is of use for estimating cable tension.

Dip/Span ratio is reported. This ratio is often quoted in building codes and is therefore useful information to have when trying to meet those codes.

Vertex count. This has use when checking if cross sections can be paneled or meshed

Direction, reported as the degrees clockwise from the Y-axis (like a compass). For example, a polyline direction of 90 degrees means that the end of the polyline is on the right of the screen when viewed in XY. This has use when checking cross sections and edge polyline directions.

If the 3DPoly is closed then only the length, mean radius, and vertex count are reported.

Line

Line type. Whether it is assigned as a Guy Link or a Cable Link

Line length. If it is a Guy Link, it's original length is reported.

Direction, reported as the degrees clockwise from the Y-axis (like a compass)

Panel

Area calculated on the 2D flat panel as a true area, ie no allowance for waste.

Width gives the width of the panel, based on the panel being placed on the roll with the panel centre line along the warp.

Length gives the length of the panel, based on the panel being placed on the roll with the panel centre line along the warp.

Panel Warp Direction, reported as the degrees clockwise from the Y-axis (like a compass). For example, a warp direction of 90 degrees means that the top of the panel is on the right of the screen when viewed in XY. This has use when checking the orientation of panels for seaming, etc.

Panel Shear Strain reports the amount of shear strain distortion that will be applied to the panel when it shapes to the original 3D shape.

Panel internal ID number.

Cable Lengths

This will take a set of 3dpolys, representing cable edges, and add together their lengths, to give the total cable length. If advanced links have been used on the corners to simulate hardware widths, then these will have a correction for the cable lengths in their extended data, and the corrections are included in the calculation if the links are selected as well.



Video: [Adjusted cable lengths](#)

Resolve corner forces

Calculates the resultant force from two 3dpolys, representing cables, that join at a point. When used you will be prompted to supply the cable tensions, with the left cable first (left defined when looking towards the mesh centre from the corner). This has use in estimating anchor forces.

Physical Model Report

Select the meshes and 3dpolys that define the model, and this tool will draw an outline of the model meshes with the mesh area, projected area, and cable lengths and cable dip/spans noted. A summary report for the whole model is printed in the MPanel Pro text window. The results are scaled into meters or feet according to the default units specified in MPanel.

Pre stress Model Report

This takes a specified membrane pre stress and calculates cable tensions and corner forces based on simple static analysis. The results are scaled into meters or feet according to the default units specified in MPanel. [Background information and suggested values here.](#)

Pre stress Link Tension Report

This reports on the modeling tensions applied to edge cables, internal cables, diagonal cables and guy links, scaled to the specified membrane pre stress, and so provides information on some model elements that are not described in the pre stress model report. The tension in stiff links (guy links) is calculated from the link stretch and the link stiffness, so to obtain an accurate result the model must be fully relaxed.

Note that on the exposed mesh edge cables that are also described in the pre stress model report there will be a discrepancy in the values for the cable tension. This is due to the different calculation methods, the pre stress model report will be more accurate, but both are just providing an estimation of the actual values. [Background information and suggested values here.](#)

Test pressure Model Report

This takes a specified test pressure and estimates the fabric stresses it produces, and then the cable tensions and corner forces based on simple static analysis. The analysis assumes that there will be no shape change during the pressure loading, so the results can only be used as an approximate guide to the estimated tensions and forces. The results are scaled into meters or feet according to the default units specified in MPanel. [Background information and suggested values here.](#)

Delete Old Objects



Color old objects after drawing



Leave old objects after drawing



Delete old objects after drawing

This button deletes the last "old objects" that MPanel Pro read before relaxing, paneling, etc.

(By default, when an MPanel Pro tool runs, the old objects are left in the drawing and colored. This allows the user to check that the new objects have a correct relationship to the old objects)

The button image indicates how the program is set to handle future "old objects". They can be set to be:

- Left in the drawing and colored
- Left in the drawing
- Deleted

In the first two cases, the old objects are added to an "old objects stack", and they can be deleted with this button on a "last used, first deleted" basis.

1.8. Technical Information

Modeling and Paneling Errors

There are several sources of error that are inherent in the modeling and panel flattening process. During the design the errors must be kept within reasonable bounds, which might reasonably be less than the intended fabric pre stress.

Modeling Error

The principal modeling error is the representation of a curved surface by a mesh consisting of flat faces joined at angles. This can lead to edge alignment problems. So if the edge is a semicircle and the mesh density say $12 * 12$, the semicircle would be approximated by a 12 segment polyline. This will give a 0.5% edge length discrepancy compared to the true arc.

The solution is to raise the model density. This is easy with the Change Mesh Density tool, but expect to need more iterations to achieve a fully relaxed model. Choose the lowest model density that will keep the errors at a reasonable level, and then the model should still relax fairly quickly.

Paneling error

In general there is inevitably an error when flattening a 3D shaped fabric to a 2D panel. There are some exceptions, such as conic surfaces and surfaces of revolution that produce zero error, but for most anti clastic surfaces as used in tensile structures there will be flattening errors. MPanel Pro uses a method to reduce the effects of these errors by sharing the errors equally in the bias directions of the panel. This error is then reported as the equivalent shear strain, see definition below. If the errors need reducing further, build with more seams.

Merging error.

When two panels are merged, if the joined seams are different curves, something has to give to let them join. The give is on the bias, and it is reported as the equivalent shear strain, see definition below.

Shear Strain

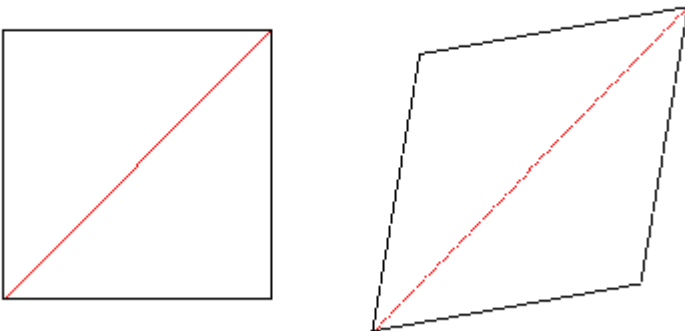

Consider a small square of fabric in the middle of a panel, illustrated on the left. If it is distorted into the rhomboid on the right the amount of stretch or shrink in the diagonals, shown in red, gives a measure of the shear strain. This is the figure that MPanel Pro reports as a percentage of the original diagonal length. So the shear strain shows how much your fabric will have to move on the bias to make the panels fit. Typically the shear strain is cumulative, so if you panel and then merge the shear strain is the sum of the strain at each stage.

If you prefer to see shear strain as an angular measurement, note that 1% diagonal change is roughly 1 degree of angular strain.

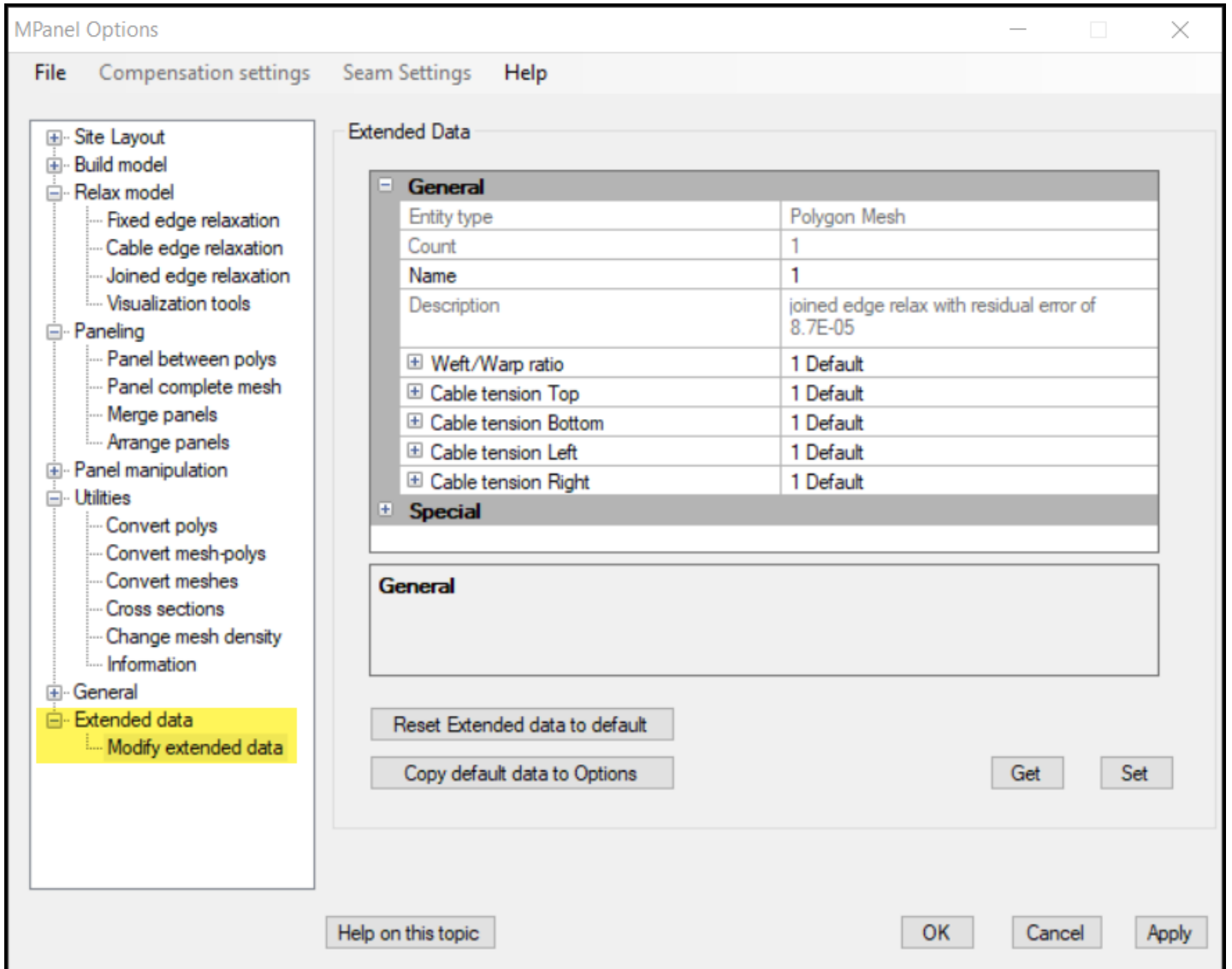

Video: [Extended data](#)

Extended data is used to record information about the mesh, link or panel drawn, and optionally to change that information to affect further relaxations.

The extended data editing is carried out on the "extended" tab in the options. Select the meshes, lines or panels and click the "Get" button. The extended data for all the selected objects will show in the text window. Shift+"Get" will show the raw data associated with the selected objects - this is for advanced information and compatibility with legacy versions of MPanel Pro and are rarely if ever used today.

To change any editable data, change the text and then click the "Set" button.

To set all extended data back to default setting, a "Set Default" button is supplied.

To avoid confusion when editing several objects at the same time a preferred method is to give significant names to each of the objects. For example select just the North mesh in a set of meshes, get its' extended data, change the object name from the default name to "North Mesh", and set the extended data. By giving each object a significant name the editing of a set of objects becomes clearer.

If several objects are selected with the same extended data (except their names) then the data will be presented as one

item called "Multiple Objects", and the data can be edited and set on all the objects from this single entry.

The vertical separator in the properties table can be moved left or right to expand description cells by left clicking and dragging the vertical separator.

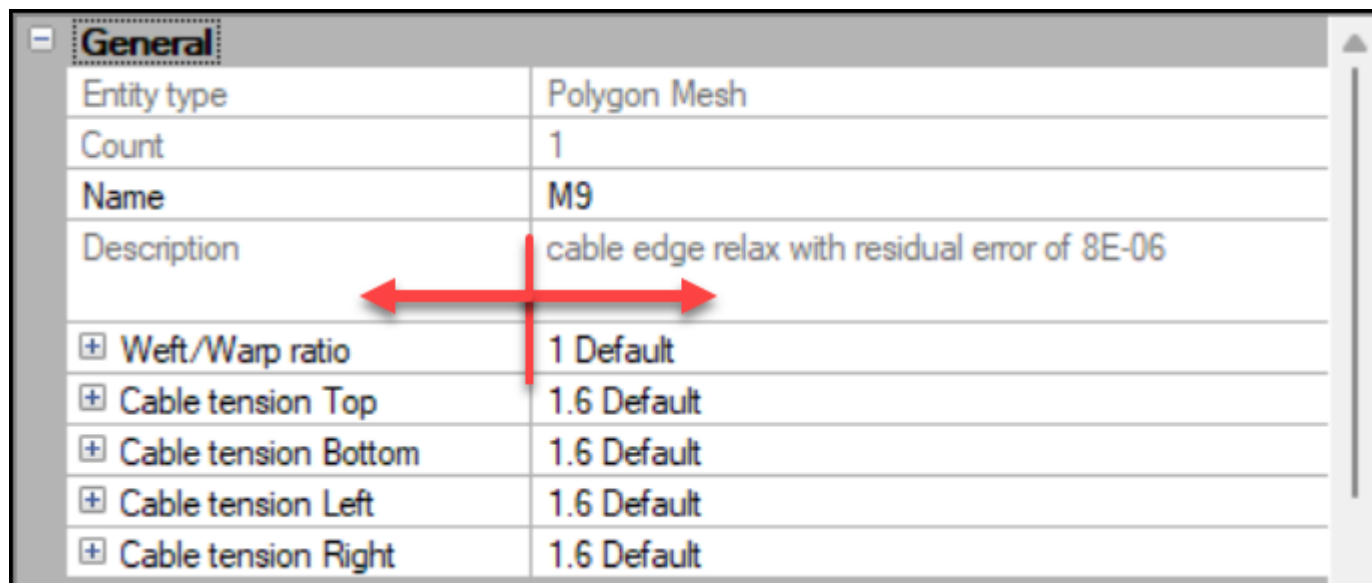

Mesh

Editable fields and example values

Name = North mesh
 Weft/Warp Ratio = Default (0.5)
 Cable Tension Top = Default (1.3)
 Cable Tension Bottom = Default (1.3)
 Cable Tension Left = Default (2)
 Cable Tension Right = Default (2)
 Special = None

If the value contains "Default", eg Weft/Warp ratio = Default, then the current option setting will be used on the next relaxation.

If the value contains a value in brackets, eg Weft/Warp ratio = Default (2), then that was the option setting value used on the last relaxation.

By altering these figures MPanel Pro can use different settings for individual meshes.

Note: In MPanel Pro v29 we changed to specifying the mesh shape with a shape factor. In extended data we use the older specification of weft/warp ratio. They translate in this manner:

Shape factor Warp=1 Weft = 1	is the same as	Weft/Warp ratio = 1
Shape factor Warp=1 Weft = 2	is the same as	Weft/Warp ratio = 2
Shape factor Warp=2 Weft = 1	is the same as	Weft/Warp ratio = 0.5

Special values can set the model to mirror the model. Or they can set the mesh basic warp tension, which is normally=1. Acceptable values are:

Special = MT or MB or ML or MR or W0.3

In addition if a special setting was used during relaxation then an "information" value is added to the special values. This is for information purposes only, and is not used as a setting. Information settings start with the letter I, and can be read as:

IV constant stress used on a legacy relaxation
 IS soft spacing turned off
 IC even tension set on the cables
 ID diagonal warp used
 IF fix modeling tension used
 IL warp straightening used

IPx a pressure of value x used

IFx concentrate warp threads stress variation used, when selected x is presently always = 1

Links

Editable fields and example values:

Name = NE Guy

Maintain = Tension / Length

Value = 4 ... the length for a guy or the tension for a cable link

Panel

There are no editable fields for a panel.

The panel edges are marked as warp edges or weft edges

A description of the tool that created the panel, and the option settings used, and the shear strain, are recorded on the warp edges.

The panel internal ID number is recorded as Panel ID = X Further panel operations such as compensation, seaming, etc will give panel ID numbers like X.Y

Reset Extended data to Default

This will set the extended data for all the selected objects to Default. So the value used on the next relaxation will be the value in the Option. A particular use of this is to enable link lengths to be changed on the screen... normally the old link length would be recorded in the extended data, and used on the next relaxation.

Copy Extended data to Options

This will read the extended data window, and try to extract unambiguous values for the last used mesh weft/warp stress ratios, and the for cable tension ratios. If these are found then the option vales will be changed to match. This has use when working on an old model, to set the options to the same values as used previously.

Using Links

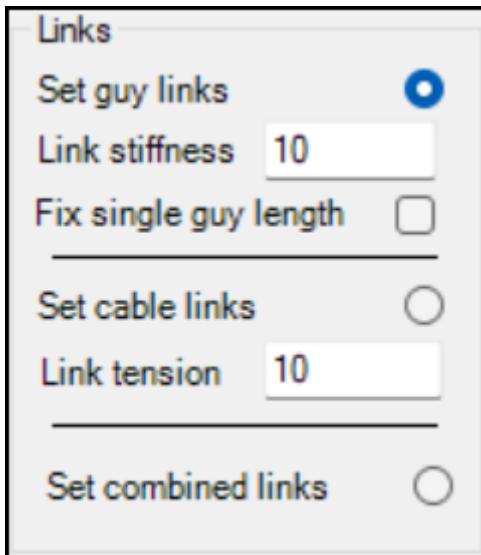

Links

Lines in the drawing are regarded as links, their type is set the first time they are relaxed by an option setting under the 'Relax Mesh Tools' tab. There are three types of links:

- Guy Links: maintain an approximately constant length, irrespective of their tension

- Cable links: maintain a constant tension, irrespective of their length.
- Combined links: maintain a constant tension, irrespective of their length.

Uses

Guy links try to maintain their initial length by means of an assigned modeling stiffness. They are used to represent corner links, turnbuckles, chains, guy lines, or poles. In use they stretch to develop a tension determined by the link stiffness.

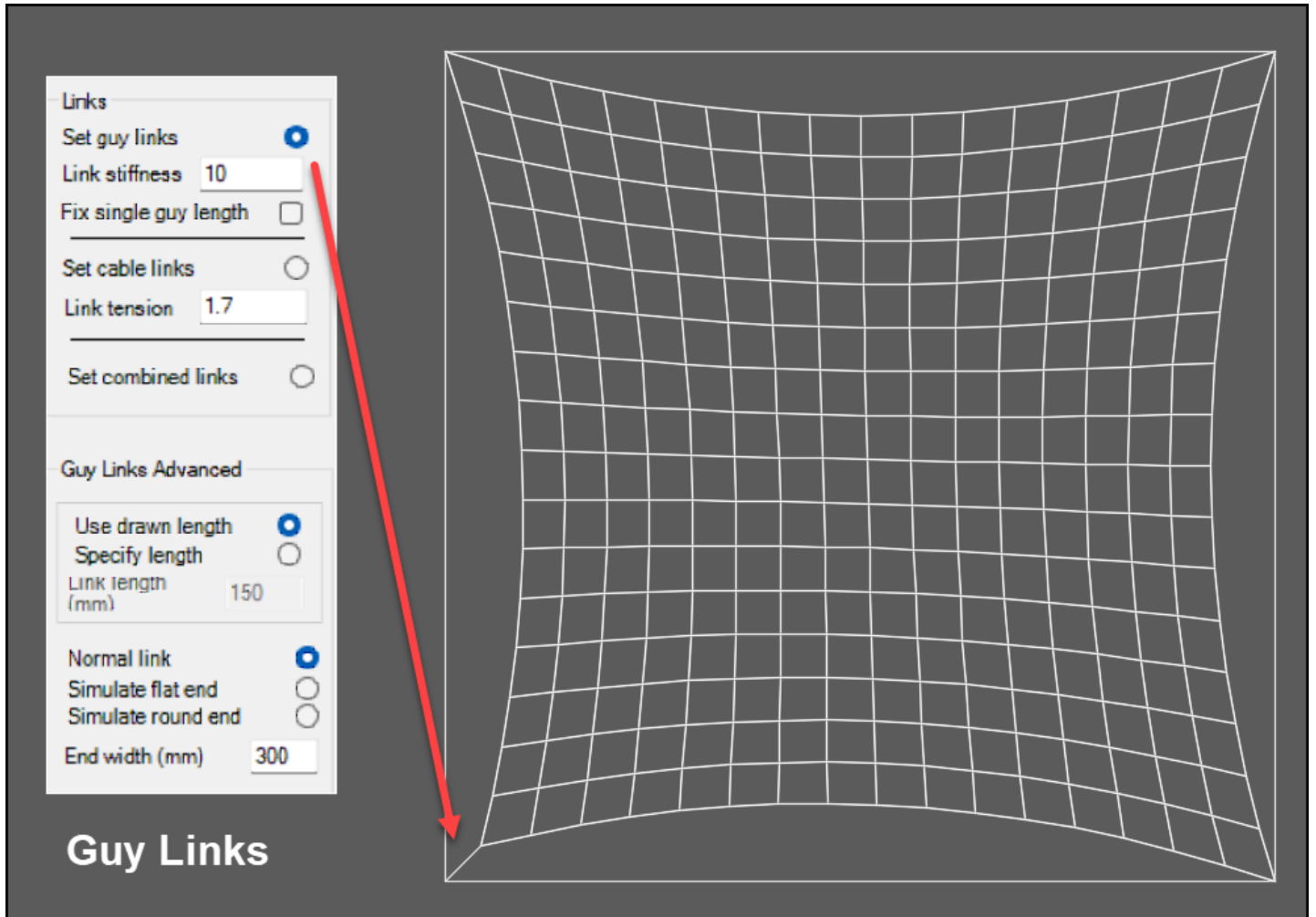

Cable links maintain their assigned tension, irrespective of length. They are used in modeling cable nets, and occasionally to represent a reinforcement belt used to create a ridge in a membrane surface.

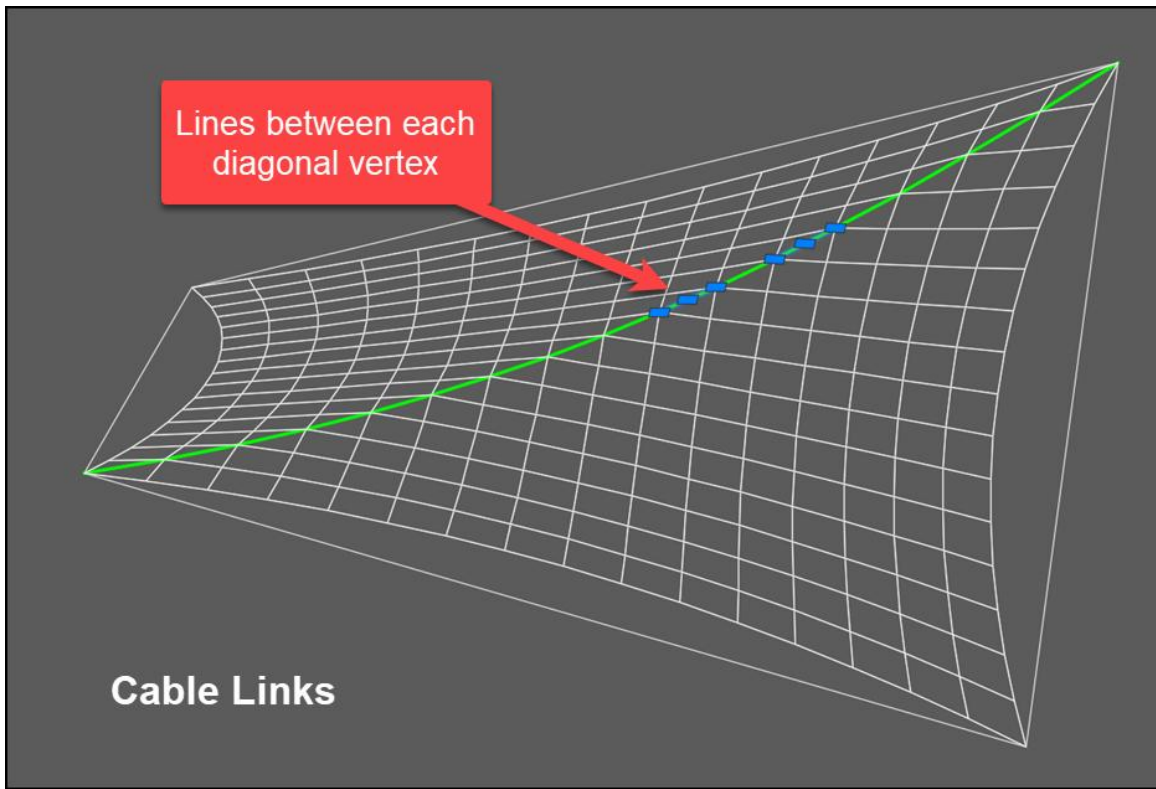

Combined links have both an initial length and an initial assigned tension. They are used when modeling cable nets and catenary cable supports. They are more stable in modeling than plain cable links.

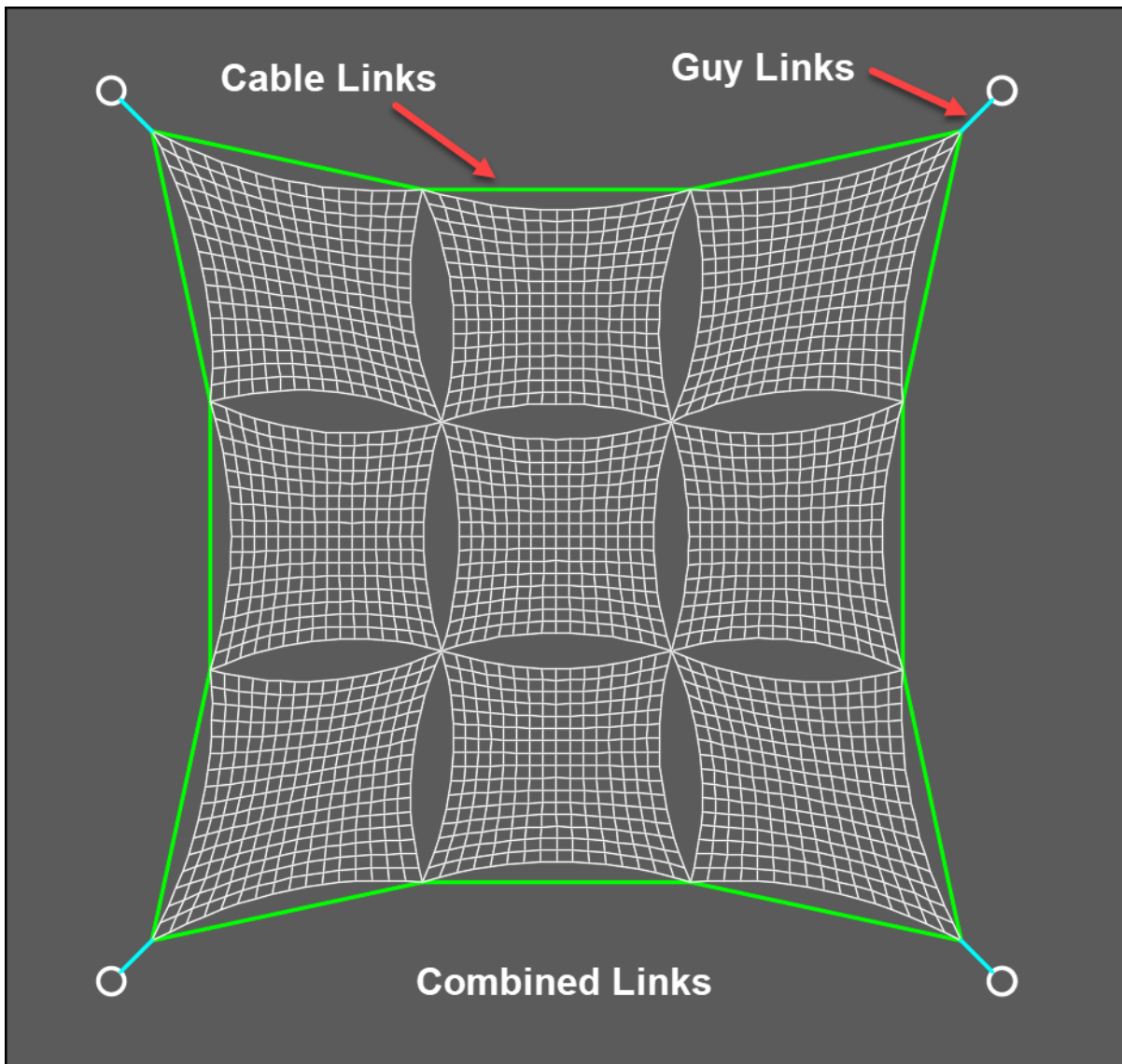

Guy Links - details

Guy links stretch during relaxation by an amount determined by the link stiffness. In general use, with a link stiffness setting of 100 a link will stretch about 1%, but the exact amount will depend on the model. Lower link stiffnesses relax better, requiring fewer iterations to find their final position, and in many cases a link stiffness of 10 is appropriate.

In the situation where corner links are required to be an exact length you can optionally force the link length to stay exactly the same length. This causes a small modeling error, usually insignificant, but will only work with isolated links when one end is fixed.

Although guy links can be in compression to represent poles or masts in general compression links have poor modeling stability and often result in the whole model collapsing to the ground.

Advanced Guy links can also simulate an end width, to allow for the truncation effect of fitting standard hardware such as D rings in the membrane corners. This is fully described [here](#)

The link original length is stored in extended data, and can be modified using the extended data editor.

Cable Links - details

Cable links have a tension specified such that a setting of 1 is equal to the average edge cable tension in the model. This means that in many cases a value close to 1 is appropriate.

When cable nets are constructed using cable links it may require careful adjustment of the link tension to avoid the model collapsing with zero length links.

The link tension is stored in extended data and can be modified using the extended data editor.



Video: [Cable links V27](#)

Combined guy and cable links - details

Combined guy and cables links have their tension determined by the link tension setting plus the tension created by stretching the link against the link stiffness. This gives a more stable modeling element to use in cable nets and catenary support structures.

Using a specified tension similar to the expected final tension (in modeling tension units where 1 equals the average edge cable tension) and a low link stiffness will allow the cable structure to change shape to accommodate the forces applied by the mesh edge cables.

Using a lower specified tension and a higher link stiffness will keep the structure closer to what was drawn, with more variation in the individual link tension.

The link initial tension and initial length is stored in extended data and can be modified using the extended data editor.



Video: [Combined links V27](#)

[Links that simulate end width.](#)

A specific problem arises when terminating membrane sail corners with standard hardware, such as D rings. The membrane corner has to be truncated to fit the hardware, and this shortens the corners by an amount depending on the corner angle. To allow for this an arbitrary length guy line is needed to make up the corner length.

This lead to the concept of an link that measures it's length between the fixed point and a point in the sail where the corner has a specified width. This allows the membrane to be designed, paneled, and then have the corners truncated to fit the hardware width, which will leave a membrane that will have the specified distance from the fixed points.

This is achieved by specifying the link as "Simulate flat end".

Simulate flat end

As an example, we have a hypar sail which will be terminated with a D ring and a snap link, shown in Yellow.

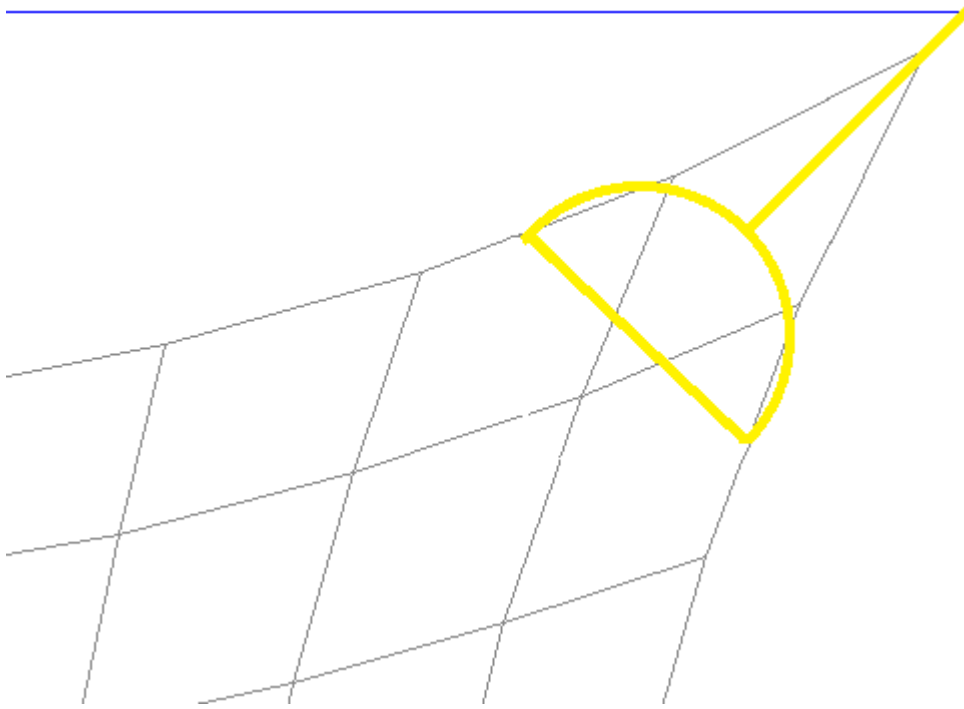

To model this we specify a flat end link in the corner that defines a link width and link length. The link length would be the internal length of the D ring and snap link coupled together. Then we relax the model to obtain the picture shown below. The relaxed link is shown in Cyan, and the points that the length and width are measured to are also shown.

So the actual link length is reduced to allow for the sail truncation needed to accommodate the D ring width. In some cases the actual link length will become zero or negative, the program copes with this OK.

The Yellow line, representing the D ring width, is shown just for illustration, it does not appear in the CAD drawing.

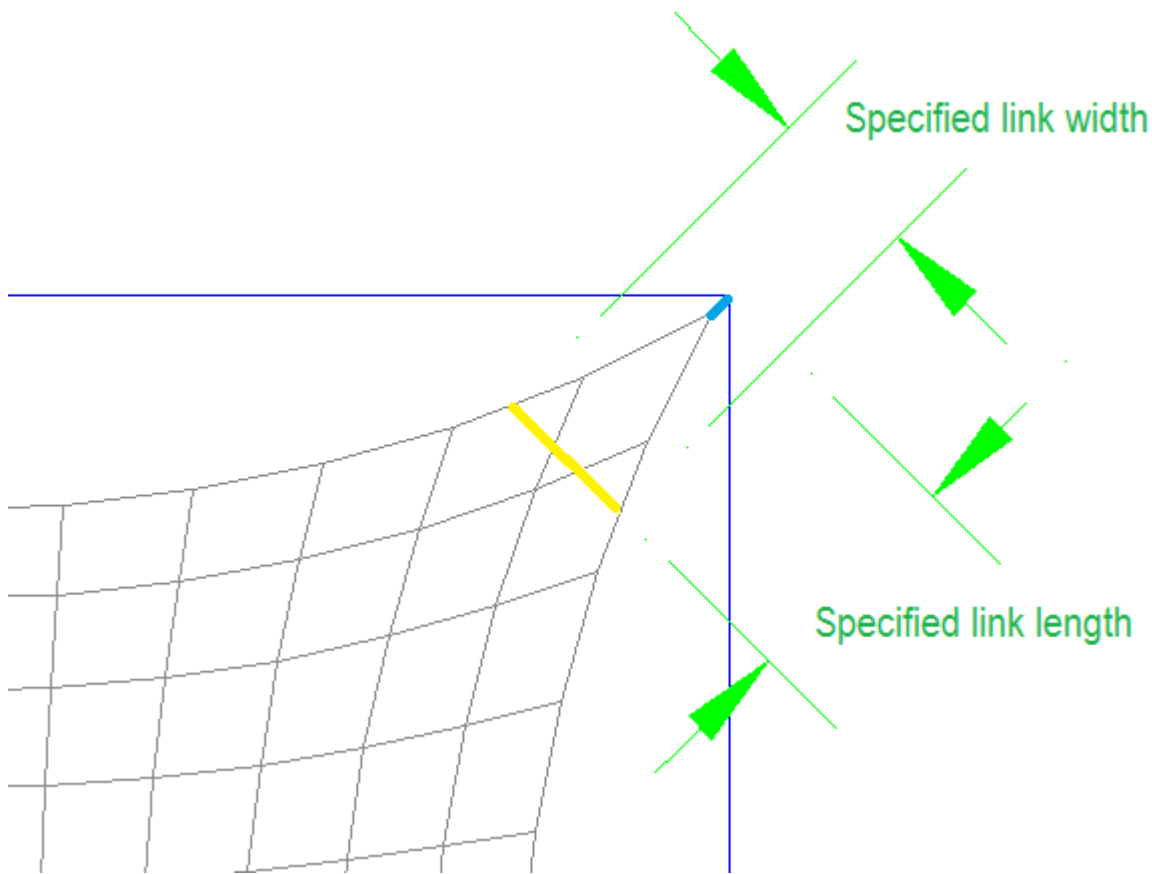

So with the above drawing, if the sail was built and hemmed, and then truncated to fit the D ring, the snap link would be the right length to fit to the corner.

Additional information about the corner is stored on the links extended data, illustrated here.

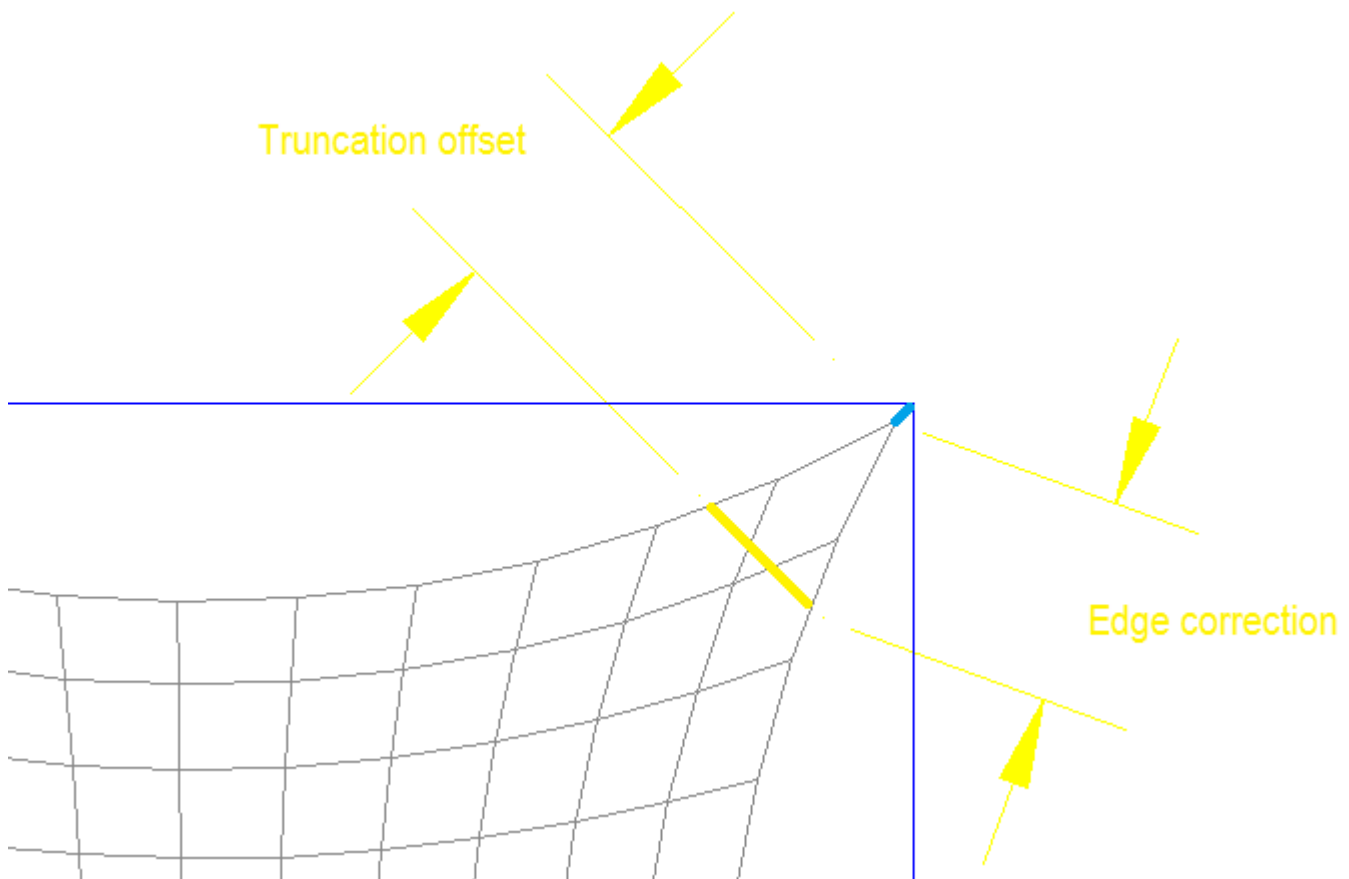

Edge Correction Amount the edge is shortened on each side of the corner.

This is used in correcting the cable length.

Link Offset

Amount the membrane is truncated in the corner for the hardware to fit. (this is measured in the 3d model, and will only be approximately correct on the panel due to compensation and shear distortion)

Simulate round end

A similar situation is where the corner hardware is built so that the cable passes around a circular groove in the hardware, like an Ez glide. In this case the circle has to fit in the membrane corner tangentially, as shown here.

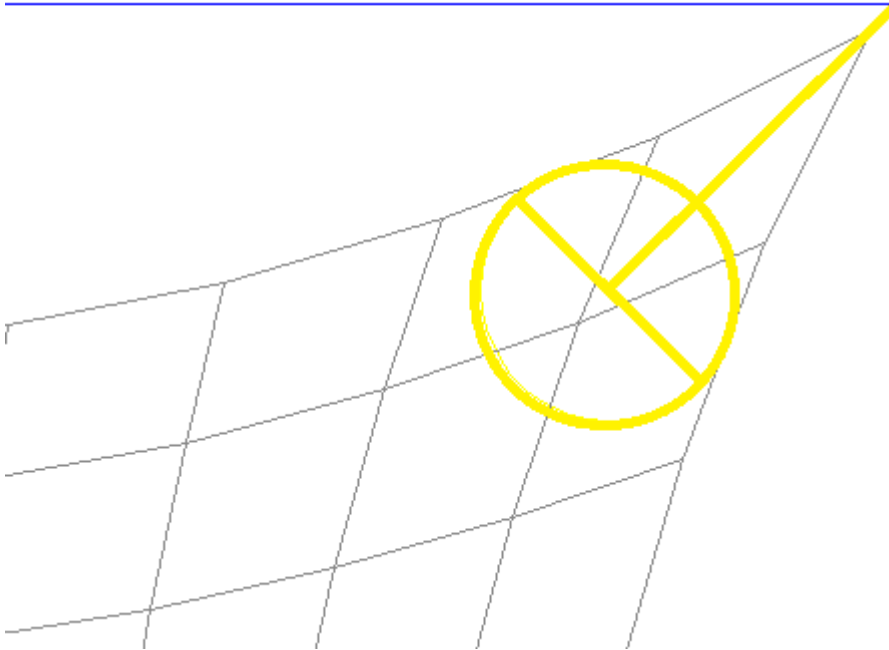

To model this we specify a round end link in the corner that defines a link width and link length. The link length would be the internal length of the Ez glide and snap link coupled together. The link width would be the diameter that we need to fit tangentially into the corner. Then we relax the model to obtain the picture shown below. The relaxed link is shown in Cyan, and the points that the length and width are measured to are also shown.

The Yellow circle and line, representing the Ez glide fitting, is shown just for illustration, it does not appear in the CAD drawing.

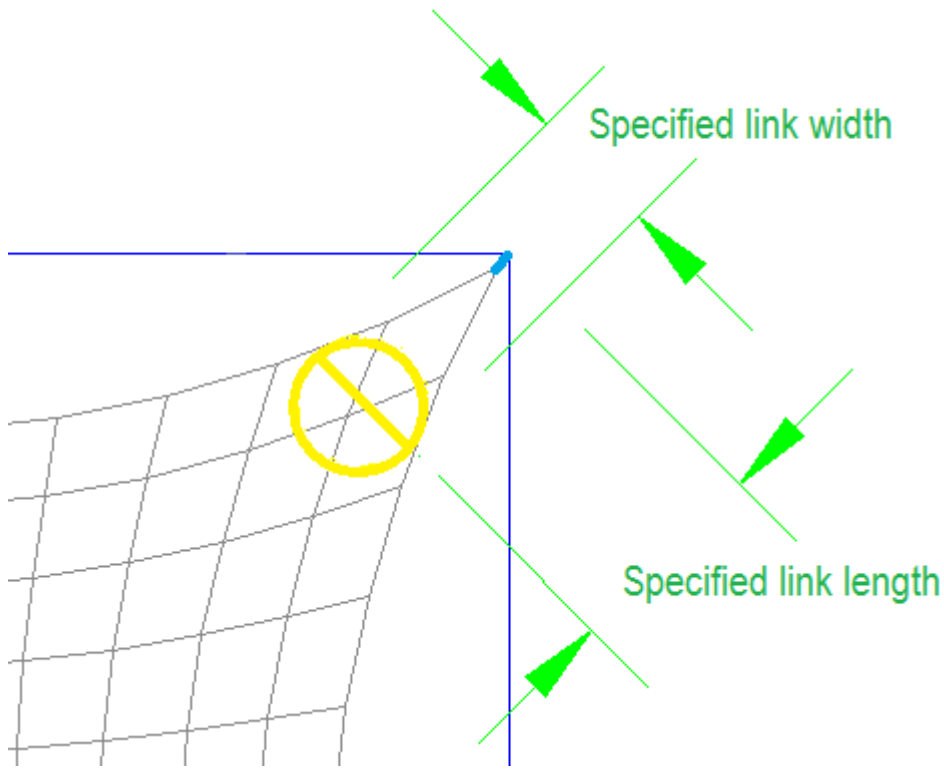

So with the above drawing, if the sail was built and hemmed, and then truncated to fit the EZ glide into the corner tangentially, the snap link would be the right length to fit to the corner.

Additional information about the corner is stored on the links extended data, illustrated here.

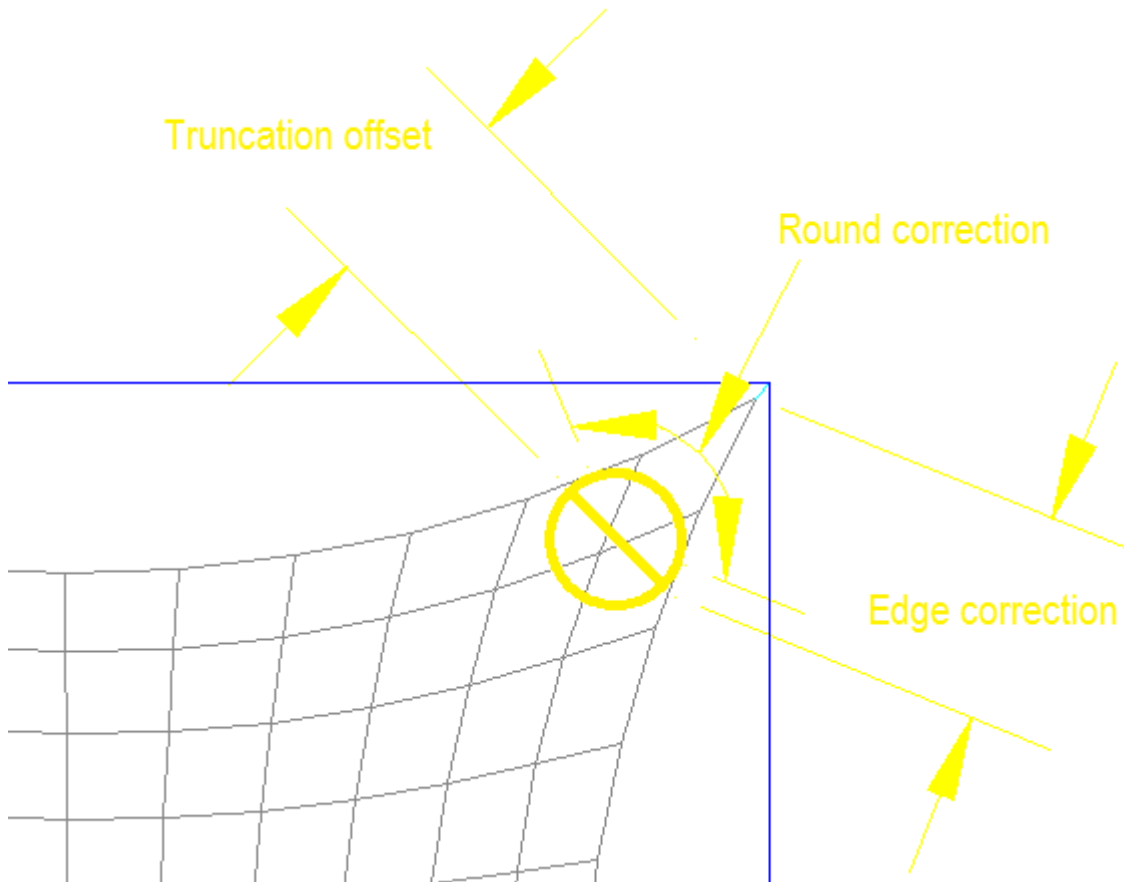

Edge Correction Amount the edge is shortened on each side of the corner. This is used in correcting the cable length.

Link Offset Amount the membrane is truncated in the corner for the hardware to fit. (this is measured in the 3d model, and will only be approximately correct on the panel due to compensation and shear distortion)

Round Correction Amount of cable used to go around the corner hardware.
 This is used in correcting the cable length.
 (only applies to round end links)

Stress Estimation

Although MPanel Pro is not a tensile structure stressing package, it can be used to roughly estimate fabric stress, edge loads, cable loads and anchor loads. This process is simplified by using the Model reports in the Info tool. For more comprehensive and accurate results, use the MPanel Pro FEA add on module.

Here we describe:

- Estimating cable tension's and corner forces due to membrane pre stress.
- Estimating stresses under load using the whole model report.
- Estimating the static stresses using hand calculations.

Estimating tensions and forces due to pre stress.

This uses a given membrane pre stress, which is assumed to be the same all over the membrane. The cable tensions are then calculated from the mean arc radius of the catenary edges, and the cable tensions are vector summed to calculate the cable forces.

Suitable pre stress values:

(actual pre stress depends on the material, the manufacturers recommendations, the structural application, and the membrane size)

Shade cloth (Knitted HDPE)	=	10 kgf/m	=	6.5 lbf/ft
Type 1 PVC coated polyester	=	200 kgf/m	=	135 lbf/ft
Type 2 PVC coated polyester	=	250 kgf/m	=	168 lbf/ft

Estimating stresses under load using the model reports.

This uses a test pressure applied to a very simplified model, based on this premise that the fabric stress under a pressure load is similar to the hoop stress in an inflated cylinder, where the cylinder radius is equal to the mesh minimum radius. From the fabric stress the cable tension can also be estimated.

A description of the reasoning behind this method is appended below. Note that this method will tend to over estimate stresses (since we ignore membrane deflections, second principle carrying stress, cable orientation, etc) but will produce membrane stress and cable tension figures that are indicative of real values where the surface is double curved with small radii. Flatter surfaces with very high radii will produce excessively high estimates of stress and cable tensions.

Suitable pressure loads:

Suction uplift from 50 mph (80 km/hr) wind	=	30 Kgf/sqm	=	6 lbf/sqft
Suction uplift from 100 mph (160 km/hr) wind	=	120 Kgf/sqm	=	24 lbf/sqft
Down pressure from 3 feet (1 meter) of snow	=	100 Kgf/sqm	=	20 lbf/sqft

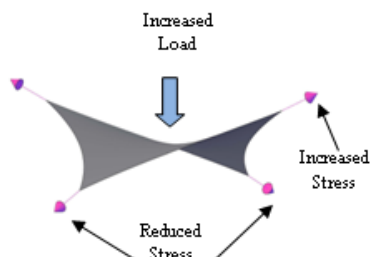

Description of method:

In a true anti-clastic tensile structure with pre-stress, there are two principle directions where the curvature is at a minimum. Under external loading, the stress in one principle direction will increase, and the other will decrease. As the external loading increases, a point will be reached where the stress becomes zero in one principle direction. (this assumes no deflection of the membrane) At this point, the increased stress in the other principle direction is solely supporting the external load. So this stress is similar to the hoop stress in an inflated cylinder, with the same radius.

Estimating the static stresses using hand calculations.

Fabric stress

At the geometric centre of the mesh, determine a reasonable stress for the fabric in warp. This could be 50 Kg/m for example.

The weft stress at this point will be warp stress multiplied by the weft/warp stress ratio, as set in the Options. With a weft/warp ratio of .33 this could be 16 Kg/m in our example.

If a normal relaxation has been performed, the stress at other parts of the mesh is related to the centre stress by the mesh density in warp and weft. So if a part of the mesh has its warp lines twice as close together as at the centre, then the warp stress there is twice as high, ie 100 Kg/m in our example.

If the constant stress relaxation was chosen in Options, the stress ought to stay constant over the mesh irrespective of mesh density.

Edge Loads

The edge load, for example in supporting steelworks, is the reaction to the edge mesh stress. If the local mesh lines are substantially at right angle's to the edge, then the edge uniform density loading is numerically the same as the mesh stress.

Cable loads

The cable tension is the total edge load along the cable length multiplied by the cable tension ratio for that edge. So a 5m long edge at 30 Kg/m edge load with a cable tension ratio of 1 has a cable tension of 150 KG, or for a cable tension ratio of 1.5 the tension would be 225 kg.

Anchor loads

The anchor loads are determined by vectorially adding the loads for the cables from that point. The MPanel Pro Info tool will perform this addition automatically, by selecting two polylines that join at a corner and specifying their tensions.

Reported base modeling tensions

After each relaxation the average width of fabric that each thread in the mesh is representing is reported in the text window, as the "model warp spacing" and "model weft spacing". These can be helpful in estimating stresses, and in determining values to be used with later FEA analysis.

For example if the fabric will be tensioned to 100 Kgf/m and the model warp spacing is 0.4 meters, the tension carried by each warp thread is 40 kgf.

The value calculated for the weft threads will have to be multiplied by the weft/warp stress ratio.

If the relaxation used the "constant stress" option, then this would be the average thread tension, adjusted according to the spacing of the threads.

When a cable link is used, the tension on the link is specified as a multiplier times the warp thread tension. So in this example if you had a cable link, with a tension setting of 5, the real cable link tension would be $5 * 40 = 200$ kgf.

If "even tension" is selected on the cable options, the theoretical base cable tension will be reported. This doesn't allow for the cable tension ratios so the value has to be multiplied by those ratios.

Adding MPanel Pro to the AutoCAD Menu

MPanel Pro is not automatically added to AutoCAD. This gives the user full control over his AutoCAD environment. To add MPanel Pro to the AutoCAD menu:

AutoCAD 2000, 2000i, 2002 and 2004

Have AutoCAD and MPanel Pro running.
Right Click on the MPanel Pro menu bar to get the Options window.

From the *File* menu, chose *Create AutoCAD Menu*.

AutoCAD 2006 and up

In AutoCAD select Tools... Customize... Interface

Select the Transfer tab

In the right hand pane, select Open and navigate to the MPanel.cui file
(usually at C:\Program Files\MPanel\MPanel.cui)

In the right hand pane, expand the menus item and drag the MPanel Pro menu to the menus item in the left hand pane.
Save the left hand pane, and then click OK

Adding to a Button, Command Alias, or Menu Item manually

The required macro string is:

(startapp "c:/program files/mpanel/mpanel.exe") for the full version

(startapp "c:/program files/mpanel/evaluation/mpaneldemo.exe") for the demo version

Internal Model

MPanel Pro reads the drawing model, the extended data, and the current options, and creates an internal model that consists just of links and nodes. This model is then relaxed, and the results written back to the original model entities. The model can optionally be drawn out during the relaxation. It has no further use to MPanel Pro once it is drawn out, but inspecting it can shed light onto the MPanel Pro process.

Each link and node in the internal model has extended data, which can be displayed in the extended data tab. The data format is as follows:

Nodes

Node Number	Node identifying number
NodeFree / NodeFixed / NodeDead	NodeStatus
SoftSpace / HardSpace	How to space the nodes in the mesh
Guyed / GuyTrim	Status of guys on the node
Linklist	A list of links connected to the node. Negative means connected to the link end

Links

Link number	Link Identifying number
Rubber / Stiff / Pressure / Dead	Link type, normal link = rubber, a guy = stiff
LocY / LoxX / LocXY / LocXX / LocYY	Link orientation, used for spacing in mesh.
Edge	Marks a cable edge
StNode	Node at link start
EndNode	Node at link end
Xten	Xtension multiplier
Yten	Ytension multiplier

During the relaxation the tension on each link is calculated as :

Link tension = Xten multiplier * base weft tension + Yten multiplier * base warp tension.

Base Modeling tensions

During the relaxation the base modeling tensions are recalculated to approximately get a stress of 1 on each edge in the fabric. If there are no meshes then the base weft and warp tensions are set to 1.

CSA Internal Model Tension Calculations

Thread tension

MPanel Pro assigns a tension to each short thread in the mesh so that the thread can represent the membrane around it, and then during the relaxation each node is moved towards a force balance position with its attached threads.

The thread tension is calculated from the adjacent cell widths, so physically it corresponds to the resultant of the fabric stress, at a nominal fabric stress of 1, over the cell width in the thread directions.

The threads that represent the weft direction have their tension modified by the weft/warp stress ratio.

The thread tensions are updated about every 10 iterations during the relaxation, which is sufficient to keep the thread tensions following the changes in the mesh shape.

Variable warp stress option

If the option "Variable warp stress" is selected then the threads that represent the warp threads have their tension replaced by an "fixed warp thread tension". This has the effect of increasing the membrane stress in areas where the warp threads are close together, and reducing it where they are wider apart.

The "fixed warp thread tension" is calculated from threads that start or end on a cable, to ensure that the shape of those cables does not change significantly when selecting this option.

On conics this has the effect of increasing the overall warp tension, which would decrease the effective weft/warp tension ratio. To avoid this the weft thread tensions are all increased by the factor "fixed warp thread tension" / "average warp thread tension". This correction is not applied to models that have cables along the mesh warp edges (ie hypars, triangular sails) otherwise it would change the shape of the warp cables.

Cables

Threads which represent cables have their tension assigned once at the beginning of each relaxation run, and it is not changed during the relaxation. The tension is related to the distance between the fixed points at the cable ends. This measurement may span several meshes.

If the cables are connected to fixed points by guys the tension assigned is still calculated on the fixed point length, so the guys are ignored and the cable tension is based on a slightly longer length than the distance between the cable ends. (There can be a maximum of 2 guys in series connecting the cable ends to fixed points)

This method of fixing the cable tension at the beginning of the relaxation based on system fixed points means that the major forces in the model are not changing during the relaxation, which helps to keep the solution stable.

Other links

If a pressure is specified it is modeled as an additional thread at each free node, normal to the local surface, with a tension calculated from the area of the cells surrounding the node.

Stiff links (guys) have a modeling stiffness set such that a stiffness of 100 means a guy will extend by 1% under typical model loading.

Cable links have a tension assigned to them which is the average of the warp thread tension, modified by the cable link tension setting in the options.

[Detail dxf specification.](#)

The detail dxf consists of these entities:

A V formed by two lines of the same length. The start of the lines is at the corner of the V. The most clockwise of the lines is colored blue, the other is green. The V is usually drawn in the "12 o'clock to 3 o'clock" position. This V is the reference that is scaled angularly and linearly to fit the V in the 3D drawing. These reference lines are not transferred to the 3D drawing

Any number of polylines that define the detail that you want to transfer to the 3d drawing.
(In AutoCAD these are polylines, not 3d polylines)
(In Rhino each polyline must have at least 3 points)

Any number of points. These will be transferred to the 3d drawing, and can be used as panel alignment marks.

The dxf should be saved as a dxf file, R14 or later. The file should be placed in this folder: MyDocuments/Mpanel/Detail
The exact location of this folder will vary depending on the operating system. If the dxf file is created in Rhino, use the

2004-Natural style for dxf export.

Notes on non scaling polys:

If a polyline is to be "Not Scaled" then it should be colored Magenta. Non scaling polylines are handled in this manner: The first point of the polyline is regarded as the reference point, and it's position is scaled angularly and linearly. The rest of the polyline is moved with the first point. So polyline representing a circle should have the first point at the circle centre.

If the entity orientation is important, say for a rectangular polyline, the second point on the polyline is used to define the part rotation during angular and linear scaling.

Notes on point sets.

If a set of points are to be joined together during paneling, they should be colored the same simple color, like Red, Yellow, Blue, Green.

If some points should not be joined together, they should be left un-colored.

DXF Output file version

The predefined DXF Output file version can be tailored by hand editing (using notepad or any text file editor) the MPanel Pro User Setting.ini file, in the users documents directory. The MPanel Pro User Setting.ini file is not changed when MPanel Pro is updated. To add this option to an existing ini file simply copy and paste the following 2 lines at the bottom of the file and save.

```
[DXF]  
Version = 14
```

By default the DXF Output file version = 14.

Alternative values are:

version 14,15,18, 21, 24, 27 or -1 for legacy method (only use this if your plotter/cutter no longer operates as it did prior to updating MPanel Pro to v25.1 or later).

If you prefer not to edit the MPanel Pro User Setting.ini file a new version of the file with these options already included can be obtained from C:\ProgramData\MPanel\Archive - this can be copied to Documents\MPanel Pro and replace old file.

Scripting

keepn

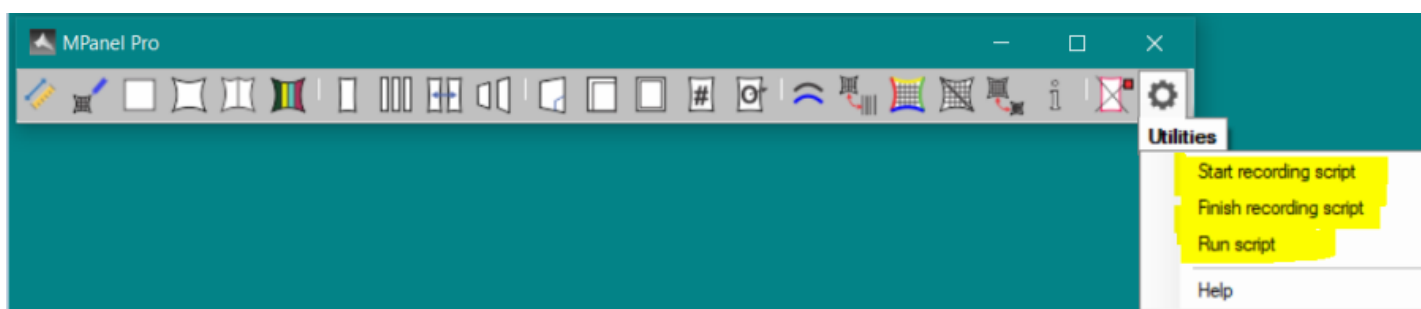

Video: [Scripting](#)

MPanel Pro can record paneling operations, and run the script for a similar but different set of panels. This allows automation of common paneling operations. An unlimited number of scripts can be recorded.

The tools that can be scripted are:

- Panel between polylines

- Panel a complete mesh
- Merge adjacent panels
- Arrange panels
- Modify a panel
- Compensate panels
- Seam panels
- Stamp panels
- Output panel
- Delete old objects

It is important to note that only MPanel Pro operations are scripted. So if you want to move, delete or copy a panel during script recording it should be done using MPanel Pro tools, rather than CAD tools

Record a script

To record a script, start the recording with the Utilities tool Start Recording. Then perform the paneling operations as you normally would .

Save a script

When you have finished your panel operations, end the recording with the Utilities tool End recording. You will be prompted for a script name to save. You can add a description of the script for future reference.

Run a script

To run a script, first select the starting entities (mesh, polylines, panels) that the script will use Then select the Utilities tool Run script You will be prompted for a script name to run. The paneling operations will occur automatically in Cad.

Build barrel vault details explained

Production parameters

Production parameters	
End arch kedars	<input checked="" type="checkbox"/>
End keder offset (mm)	50
Internal arch kedars	<input type="checkbox"/>
Internal keder offset (mm)	25
Internal arch trim (mm)	150
Trim end arches to cable	<input checked="" type="checkbox"/>
Cable dip/span %	8
more information	

End keder offset

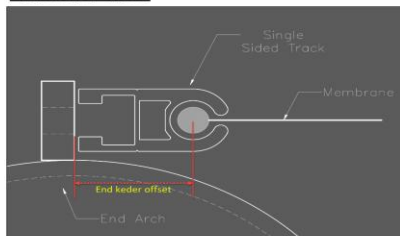

Internal keder offset

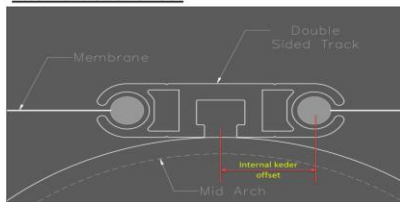

Internal arch trim

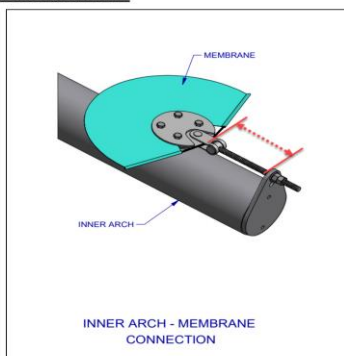

Trim end arch to cable

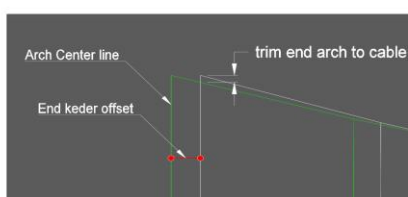
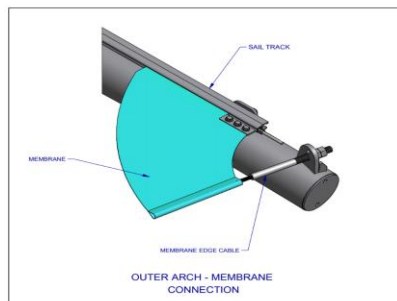

1.9. Quick Reference

Quick Reference (entities)

MPanel Pro places special meaning on some drawing entities to define the model for relaxation. These entities are:

Mesh

A mesh is treated as a surface to relax. Meshes are usually created using the MPanel Pro Model builder

3D Polyline

A 3D polyline is used to define fixed points on a relaxation. Mesh points or link ends that are coincident with the 3D polyline vertices are fixed during the relaxation. Fixed points are typically anchor points, tops of masts, or fixed edges on the relaxations.

Line

A line is used to define a link, which could represent a guy, mast or a section of a cable. Several links can be joined together to define a structure.

AutoCAD specific notes

Polylines, LW Polyline, 2D Polylines are flat polylines that are only used for panels or panel details. They are not recognized as entities in the 3d model.

A mesh can also be drawn directly in AutoCAD using commands such as EdgeSurf or 3D Mesh. There is also limited read support for polyface and sub-dividable meshes, as long as they are regular. (Sub-dividable mesh's were introduced in AutoCAD 2010, AutoCAD refers to them just as "Meshes")

Rhino specific notes

A mesh can also be drawn directly in Rhino using commands such as MeshPlane. Meshes have to be regular meshes, ie an ordered set of rectangular mesh elements, like a plane mesh.

Polylines are a curve with a degree of 1, and more than two points

Lines are a curve with a degree of 1 and exactly two points.

Rhino default model space scaling - this should be set to 1 to ensure accurate panel text stamping - see video:



Video: [model space text scaling](#)

Quick Reference (tools)

[Site Layout](#)

Use this to help convert site measurements into a 3d drawing in your CAD system

[Model Builder](#)

Set model options and click on "Model Builder" to create the prototype drawing. Move nodes around to meet your boundaries; you are then ready to relax the model. Or use the Model Library to draw a complete model to your specifications.

[Relax Fixed Edge Meshes](#)

Select some meshes. Run the tool to relax the mesh towards a stress balanced surface, with fixed edge boundaries.

[Relax Cabled Edge Meshes](#)

Select some meshes and some 3D polylines that define the structure fixed points. Run the tool to relax the meshes including the cable edges.

[Relax Joined Edge Meshes](#)

Select some meshes and some 3D polylines that define the structure fixed points. Run the tool to relax the meshes including the cable edges.

[Model Visualization](#)

Shows graphical model information such as gradient, curvature, sun shadow, etc.

[Panel between Polylines](#)

Select two 3D polylines, and run the tool to produce the flat panel development. Optionally select a set of 3D poly's and run the tool to produce a single merged panel.

[Panel Mesh](#)

Select a mesh. Click on "Panel Mesh" to produce a series of flat panel developments. Optionally the number of panels can be specified.

[Merge Panels](#)

Select panels "A" and "B" that are alongside each other. Clicking on "Merge Panels" will produce a merged panel created by joining "A" and "B" together.

[Arrange panels](#)

Arranges panels into an ordered set, optionally between lines representing the roll width.

[Panel Detail](#)

Allows panel detail, such as corner plates or graphic markers, to be added or edited in the panel. Draw the detail as polylines, then select the detail and the panel and Click on "Panel Detail"

[Compensate Panel](#)

To shrink the panel slightly to introduce pre stress. Select the panel and click on "Compensate Panel".

[Seam Allowance Panel](#)

To add material for a seam, and optionally add guidelines and guide marks to the panel. Select the panel and click on "Seam allowance".

[Panel Production](#)

To orient the panel, stamp it with a panel name and warp line, and create a node list. Select the panel and click on "Stamp Panel".

[Panel Output](#)

To make a panel suitable for direct cutting on a plotter/cutter. Select the panel and click on "Panel Output".

[Convert Polys](#)

Convert polylines, arcs, etc to 3D polys and change 3Dpoly properties. Select the entities and click on "Convert Polys"

[Convert Mesh/Poly](#)

Convert between a mesh and a set of polylines, and vice versa. Select the entities and click on "Convert Mesh/Poly"

[Cross Section](#)

To make cross section on meshes, often to panel between. Draw cutting lines above the meshes. Select the cutting lines,

and the meshes, and click on "Cross Section".

[Change Mesh Density](#)

To change the msurf and nsurf of a mesh to reduce the time it takes to create a high definition model.

[Information Button](#)

Select a Mesh, 3D polyline, pair of touching 3D polylines, or a Panel and click on "Information". Or select the complete 3D model, and specify a "Whole Model Report".

[Delete Old Objects](#)

To delete the last old objects, ie the entities that MPanel Pro read in the drawing before running a tool.

Index

3

3 sided, 20
3D, 110
3D poly, 24, 114, 46, 76, 79, 110

4

4 sided, 20

5

5 sided, 20

6

6 sided, 20

A

across, 50
adjacent, 61
Aeronaut, 73
arch, 112
arrange, 55, 111
assembly, 71
auto, 24
AutoCad, 9, 108
automate, 111
Automatrix, 73
awning, 36

B

barrel, 36
basic use, 5
bend, 24
Blackman & White, 73
Build, 24
button names, 5

C

cable edge, 37
cables, 37, 91, 99, 109
Carlson, 73
change CAD, 5
Change Mesh Density, 89, 37, 50, 79, 114,
clamp plate, 24, 68
color, 46, 81
colour, 46, 81
combined, 99
compensate, 66, 111
Compensate Panels, 46, 50, 66
computer, 5
Cone, 24
conic, 24, 36, 37
contact, 18

convert, 73, 76, 79
Convert Mesh /Polylines, 24, 46, 79, 114
Convert Meshes, 10, 24, 81
Convert PolyLines, 76, 114
corner, 91
Corner Mesh, 24
Cross Section, 50, 84
CSA Internal model tension calculations, 37, 109
curvature, 43
curves, 20
cutout, 61
cutter, 73
Cycling, 24

D

default, 96
Delete, 94
Density, 24, 89, 114
Detail, 61, 110, 114
detect, 24
diagonally, 50
direction, 37
double, 89
D-Ring, 102
droop, 37
dxf, 73
dxf specification, 110

E

Eastman, 73
Edge Mesh, 24
email, 18
Entities, 46, 114
Errors, 96
evenly, 61, 84
Extended Data, 37, 96, 109
extra, 84
ezy-glide, 102

F

Factor, 37
File, 5
fix edges, 24, 84
Fixed, 50
flat, 46
float, 24, 37
fold, 68
force, 91
form finding, 5
framed shade, 36
FSS, 24, 36, 81

G

Geodesic, 84
Getting Started, 5, 37

Glossary, 9, 12
guys, 37, 99

H

History, 3
hole, 43
hypar, 24

I

Information, 91
Information Button, 91, 114
install, 5, 24
Internal Model, 109
interpolate, 76

J

join, 76, 81
joined, 37

K

Keder, 112

L

lap, 68
layers, 73
length, 91
library, 5, 20
Library Model Builder, 24, 36, 37
License, 12, 76, 91
line, 109, 114
Links, 99, 102, 109
Links that simulate end width, 102, 46
lofting, 37, 68

M

mark, 61
Menu, 108
Merge Panels, 37, 53, 89, 96, 111
mesh, 24, 46, 50, 79, 91, 114
mirror, 61, 81
Model, 24, 91, 96, 99
Model Builder, 24, 37
modify, 111
Modify Panel, 61, 114
move, 5
MPSD, 24
msurf, 89

N

nest, 55, 58
net, 99
new features, 3, 24
node, 109
normal, 50
notches, 73
nsurf, 89

number, 46, 71

O

OBJ, 43

optimization, 58

output, 111

P

panel, 46, 50, 53, 58, 61, 66, 71, 91, 96, 111

Panel Arrange, 55, 111

Panel between Polylines, 46

Panel Output, 73, 111

Panel Stamp, 71

parametric, 20

patch, 61

Pathfinder, 73

plotter, 73

pocket, 68

pole tent, 36

Polylines, 76, 114, 79, 91

pressure, 91

prestress, 91

Production, 71

Prosail, 73

Q

Quick, 114

Quick Reference (entities), 114,

R

ratio, 37

reaction, 24, 61, 91

rebate, 68

Reference, 114,

reinforcement, 68

Relax, 37

renumber, 76

report, 91

reverse, 76

Rhino, 9, 114

Rhino5, 5

ring, 102

rio, 68

rope, 68

rotation, 58

round, 102

S

sag, 37

sail, 20, 24

scaling, 114

Scripting, 111

Seam Allowance, 68

seams, 43, 68, 111

Selection, 24

settings, 5, 73
Shape, 37
Shear Strain, 9, 53, 96
shrink, 66
site, 20
skeleton, 73
sketchup, 5
slip, 102
slit, 68
smooth, 20
SMRE, 73
space, 55, 58
special, 96
spline, 73, 76
split, 61, 81
spread, 55, 58
stamp, 71
start, 76
stress, 37, 107, 109
Stress Estimation, 107
Stretch, 66
subscription, 5
support, 5, 18
swap, 61, 81

T

tensile, 9
tension, 37, 91, 109
Tent, 24, 36
terms, 9, 12
thread, 109
training, 5
transfer to new computer, 5
tri, 46, 50
tubes, 24

U

Undo, 94
update, 5

V

variable, 66, 109

W

warp, 37, 61, 71, 81, 109
weft, 61, 81
What's New, 3
width, 50, 61, 84
workflow, 5

X

XY coordinates, 20
xzy coordinates, 20

Z

